



**GreenLeaf**



**built**



*expect the best*

A.B.N 15 009 687 076  
DIVISION OF ELECTRICAL AGENCIES PTY LTD  
EST. 1932

**HEAD OFFICE & QUEENSLAND WAREHOUSE**  
WAREHOUSE 2, 97 FREIGHT ST, LYTTON,  
QLD, 4178, AUSTRALIA

**VICTORIAN OFFICE**  
2/11 BROUGH ST, SPRINGVALE, VIC, 3171

PHONE 1800 255 508    FAX 1800 640 073  
HEAD OFFICE 07 3906 2999    FAX 07 3906 2900

**AUSTRALIA WIDE REPRESENTATION**

[sales@electaserv.com.au](mailto:sales@electaserv.com.au)

[www.electaserv.com.au](http://www.electaserv.com.au)

# Electaserv

## Our Mission

"To provide the right products at the right price to optimise the retail success of our customers."

## 2019/20

## About Us

ELECTASERV TRADING (Electrical Agencies Pty Ltd) imports and wholesales power tools, household cleaning products, DIY products, hand tools and general hardware items. The business commenced trading in 1932 and incorporated in 1958. Electaserv products are marketed under the following brands,



Electaserv has a warehouse and sales office in Queensland & a Victorian office. We are committed and focused on our core business areas - and have built a team with vast experience to service all of these markets. We are dedicated to providing excellence in service and support through Sales, Customer Service, Warehouse and Logistics and Marketing.

## Contact Details

Electrical Agencies Pty Ltd Trading as Electaserv Trading

ABN 15 009 687 076

Address - Warehouse 2, 97 Freight Street, Lytton, QLD, 4178, Australia

Postal Address - PO Box 842 Morningside, QLD, 4170

Telephone - 07 3906 2999 & 1800 255 508

Fax - 07 3906 2900 & 1800 640 073

Email - [sales@electaserv.com.au](mailto:sales@electaserv.com.au)

NAME	TITLE	PHONE	NAME	TITLE	PHONE
Matthew Clark	Joint Manager Director	07 3906 2914	Territory Managers		
David Clark	Joint Manager Director	0447 761 617	Brendan Collins	VIC, SA	0450 604 563
Trevor Dore	Internal Sales	07 3906 2966	Stephen Clark	NSW, VIC	0448 064 000
Roneeta Prasad	Accounts	07 3906 2940	Bruce Dale	North QLD	0408 158 830
Bruce Dale	Sales Manager	0408 158 830			

## PRICES

All prices shown are Nett wholesale price and do not include GST. We reserve the right to change pricing and specifications without notice. Updated price lists are available upon request.

## RESERVATION OF TITLE

The ownership of any goods purchased from Electaserv does not pass to the purchaser until payment is received in full.

## SPECIFICATIONS

Specifications quoted are approximate and subject to commercial tolerances. Specifications are subject to change without notice.

## PACK QUANTITIES

Pack quantities are subject to change without notice.

## MINIMUM ORDER

All orders less than \$300.00 before GST is subject to a \$15.00 handling fee. Freight is at your cost.

Melbourne, Adelaide, Perth minimum order value is \$500 before GST. All orders below \$500 before GST are subject to a \$15.00 handling fee.

Freight is at your cost.

Hobart minimum order value is \$800 before GST. All orders below \$800 before GST are subject to a \$15.00 handling fee. Freight is at your cost.

## DELIVERY

Brisbane & Sydney FIS \$300 minimum order

Melbourne, Adelaide, Perth FIS \$500 minimum order

Hobart FIS \$800 minimum order

Country FOB

Orders less than \$300/\$500/\$800 are freight plus \$15.00 handling fee

## CLAIMS & RETURNS

All claims must include the invoice number and date of purchase. All goods returned must be authorised by our office and accompanied with appropriate credit documentation. Claims for incorrect, short delivery or damaged goods must be notified in writing within 7 days from the date of delivery. When the buyer has nominated a carrier for delivery of goods, responsibility of loss or damage passes to the buyer upon delivery to the carrier. Claims for faulty goods must be notified in writing immediately upon discovery of fault. Faulty goods returned will be tested and credited where workmanship or materials have been proven defective against manufacturer.

ROK Claims - Please contact your sales representative for authorisation.

## WEB PAGE

Check out our website at [www.electaserv.com.au](http://www.electaserv.com.au) Search our online product guide and keep up to date with the latest news and product releases. The ROK Power Tools website is at [www.rokpowertools.com.au](http://www.rokpowertools.com.au)

The Rok logo features the word "Rok" in a bold, italicized, green sans-serif font. A horizontal green line is positioned directly beneath the letters.

POWER TOOLS

The words "POWER TOOLS" are written in a bold, white, sans-serif font. They are centered within a solid black horizontal band that spans across the middle of the page.

# ROK

## POWER TOOLS



### Introduction

Electaserv launched ROK in June of 2008 and has continued to increase market share through the excellent quality, service and advice from our National Sales Team. Electaserv has positioned ROK power tools at a mid range level catering for both DIY and lower level trade users.

ROK Power Tools currently supply the market in the following categories: Power Garden, Portable Power Tools, Bench Top Machinery, Industrial – Cement Mixers, Cooling – Fans.

Our warranty procedure ensures a quick and easy answer for the end user in turn giving your staff more time to focus on customer service.

Further information can be found on our website at [www.rokpowertools.com.au](http://www.rokpowertools.com.au)

### Warranty

- 24 month Home User **replacement** warranty on portable Electric tools
- 12 month Home User **repair** warranty on Petrol, Bench Top & Industrial
- 6 month Trade User **replacement** warranty on portable Electric tools

#### ROK Video's How to

See how to answer questions regarding ROK Petrol Products go to [www.rokpowertools.com.au](http://www.rokpowertools.com.au) Check out the Video's

### Warranty Procedure

- 24 month Home User replacement warranty on portable Electric tools.

If a store deems that a product is faulty within the warranty period and not from user misuse, they can immediately replace the product.

To claim the faulty product simply remove the Compliance Plate (shown below) from the product and post it along with your credit claim and a copy of the customers receipt to PO Box 842, Morningside, QLD, 4170. The claim will be processed within 14 days of receiving your claim and tags.



### ROK Claims

#### Please Note

Contact Your Sales Representative Regarding Any ROK Claims

- 12 month Home User **repair** warranty on Petrol, Bench Top & Industrial.

For all warranty enquires regarding Petrol, Bench top and Industrial products contact our internal sales team on (07) 3906 2999 for further instruction.

- 6 month Trade User **replacement** warranty

If a store deems that a product is faulty within the 6 month warranty period and not from user misuse, they can immediately replace the product. Follow the procedure detailed previously under the 24 month home user replacement warranty to claim the faulty product.



**Cordless Drills  
Cordless Screwdriver Li-ion**



**Bench Top Tools  
Drill Presses  
Drop Saws**



**Impact Drills  
Rotary H-Drills**



**Power Garden  
Line Trimmers  
Chain Saws  
Hedge Trimmers**



**Demolition Hammer**



**Cement Mixers**



**Angle Grinders**



**Fans  
Floor  
Pedestal  
Drum  
Mist**



**Jig saws  
Circular saws  
Reciprocating**



**Paint Mixer  
Routers, Heat Gun  
Electric Spray Gun**



**Orbital Sanders  
Buzz Sander  
Belt Sander**



**Portable Compressor**

**18V 1.3AH LITHIUM CORDLESS DRILL**



Model No.150-19-50484

Voltage: 18V  
V/F: 240V/50Hz  
Battery: 2 x 1.3Ah Lithium Ion  
No Load Speed: 0-750RPM  
Charging: 1hr quick charge  
Chuck: 10mm keyless chuck  
Torque Settings: 21 + 1 positions  
Max Torque: 22NM  
LED lighting  
LED battery indicator  
Barcode 9326548504840



**1.3Ah**

**18V 2.0AH LITHIUM CORDLESS DRILL**



Model No.150-19-50476

Voltage: 18V  
Battery: 1 x 2.0Ah Lithium Ion  
No Load Speed: 0-350/1-1200RPM  
13mm single sleeve keyless chuck  
Charging: 1hr quick charge  
17 + 1 torque settings  
Max Torque: 25NM  
LED lighting  
LED battery indicator  
Two speed gear box  
Portable belt buckle  
Barcode 9326548504765



**2.0Ah**

**18V 2.0AH LITHIUM CORDLESS DRILL**



Model No. 150-19-50477

Voltage: 18V  
Battery: 2 x 2.0Ah Lithium Ion  
No Load Speed: 0-350/1-1200RPM  
13mm single sleeve keyless chuck  
Charging: 1hr quick charge  
17 + 1 torque settings  
Max Torque: 25NM  
LED lighting  
LED battery indicator  
Two speed gear box  
Portable belt buckle  
Barcode 9326548504772



**2 x 2.0Ah**

## 3.6V LITHIUM SCREWDRIVER



LED Light



Model No.150-77-50374

Voltage load speed:180RPM  
Charge time:3-5 hours  
Ctn Qty:10Pcs  
Ctn Size:49x23x29cm  
Ctn Weight:6kgs  
With light for working conveniently  
Accessories:11pc 25mm bits,2pcs 50mm bits,1pc Magnetic connector  
Barcode 9326548503744

## ENGRAVING TOOL



Model No. 150-21-52101

Ideal for engraving gifts, valuables and electrical items.  
Spare Engraving Tip included  
Ctn Qty.: 5Pcs  
Ctn Size: 45x31x26cm  
Ctn Weight: 9kgs  
Barcode 9326548521014

## 40 WATT GLUE GUN

Model No.150-34-38128

Power: 40W 240Vac  
Preheat Time: 3-5 minutes  
Plastic Flow: 8-12GM  
Includes 10 Glue Sticks  
Blow Mould Case Packing  
Ideal for arts and crafts  
Ctn Qty: 20  
Ctn Size: 43 x 25 x 42cm  
Ctn Weight: 11.5kg  
Barcode: 9326548381281



## 500W IMPACT DRILL



Model No.150-19-50004

Input Power:500w 230-240vac 50hz  
 No-load Speed:0-2900rpm  
 Max Drilling Capacity:13mm  
 Ctn Qty:4pcs  
 Ctn Size:54x29x27.5cm  
 Ctn Weight:14kg  
 Soft Grip  
 13mm Keyless Chuck  
 Lock-on Button For Extended Use  
 Reversible  
 Variable Speed Control  
 Accessories:1pc Front Handle,1pc Depth Gauge  
 Barcode 9326548500040



13mm Keyless Chuck



Variable Speed



Handle With Comfortable Grip



## 910W IMPACT DRILL



Model No.150-19-50005

Input power:910W  
 V/F:230V/50Hz  
 No-load Speed:0-2800RPM  
 Max drilling capacity:  
 Concrete: 16mm Wood: 25mm Steel: 13mm  
 Ctn Qty: 3Pcs  
 Ctn Size: 43.5x31.5x29cm  
 Ctn Weight: 15kgs  
 Ergonomic handle with soft grip for increased comfort  
 Variable speed control  
 Lock-on button for extended use  
 Forward and reverse rotation convenient operating  
 13mm keyless chuck  
 Aluminium front housing for durability and prolonged life  
 Two colour front handle  
 Accessories: 1pc front handle,1pc depth gauge  
 Barcode 9326548500057



13mm Keyless Chuck



Variable Speed



Aluminium Front Housing



Two Colour Front Handle





**1100W IMPACT DRILL**



Model No.150-19-51006

Input Power:1100w 230-240v 50Hz  
No-load Speed:0-1100/0-3100RPM  
Chuck:13mm metal keyless chuck  
Max drilling capacity:Concrete:13mm  
Wood:25mm  
Steel:10mm

Ctn Qty:2Pcs  
Ctn Size:41x41x27cm  
Ctn Weight:14kgs

Two speed  
Lock-on button for extended use  
Reversible  
13mm metal keyless chuck  
Aluminium front housing  
Accessories:1pc front handle,1pc depth gauge  
Barcode 9326548510063



13mm Metal Keyless Chuck



Aluminium Housing



Function Switch



Variable Speed

**800W ROTARY HAMMER DRILL**



Model No.150-19-50424

Input power:800W  
V/F:230V/50Hz  
No-load speed:850rpm  
Impact rate:  
Impact energy:4J  
Ctn Qty: 4  
Ctn Size: 51.5 x 41.5 x 30.5cm  
Ctn Weight: 24kg  
BMC with SDS type shank drills & chisels  
Barcode 9326548504246



**1100W ROTARY HAMMER DRILL**



Model No.150-19-50425

Input power: 1100W  
V/F: 230V/50Hz  
No-load speed: 950rpm  
Impact rate: 4200 IPM  
Impact energy: 5J  
Ctn Qty: 2  
Ctn Size: 43.5 x 25 x 35cm  
Ctn Weight: 14.5kg  
BMC with SDS type shank drills & chisels  
Barcode 9326548504253



**1700W DEMOLITION HAMMER**



Model No. 150-36-50427

Input power: 1700W  
V/F: 230V/50Hz  
No-load speed: 1850rpm  
60 j Impact  
Impact rate: 1850 IPM  
Ctn Qty: 1  
Ctn Size: 71 x 16.5 x 30cm  
Ctn Weight: 22kg  
Metal case & chisels with 30mm hex shank  
with D size side handle  
Barcode 9326548504277

**TRADE**



Quick Release



Lock on Button



**150W ORBITAL SANDER**



Model No. 150-76-50257

Input Power: 150W  
230V 50Hz  
No load speed: 12000 OPM  
Pad size: 187x90mm  
Ctn Qty.: 4Pcs  
Ctn Size: 52.5x30x33.5cm  
Ctn Weight: 16kgs  
Soft grip  
1pc Dust connector, 1pc sanding paper  
Barcode 9326548502570



Soft Grip



Dust Connector



**180W RANDOM ORBITAL SANDER**



Model No. 150-76-50479

Input Power: 180W  
No Load Speed: 11000RPM  
Pad Size: 125mm  
Soft grip  
Ctn Qty: 10  
Ctn Size: 64.5 x 27 x 32cm  
Ctn Weight: 16kg  
Barcode 9326548504796



**200W PALM SANDER**



Model No. 150-76-50258

Input Power: 200W  
230-240V 50Hz  
No load speed: 15000 OPM  
Pad size: 140x140x80mm  
Ctn Qty.: 4Pcs  
Ctn Size: 54x30x29.5cm  
Ctn Weight: 9.5kgs  
Soft grip  
9 Pcs 140x140x80mm sanding paper  
9 Pcs Rhombus sanding paper  
1 Pc. Irregularly shaped sanding base  
Barcode 9326548502587



**18PC SANDING SHEET**

Model No. 150-76-50212

To Suit 50258 Buzz-Sander  
Ctn Qty: 100  
Ctn Size: 47 x 43 x 37cm  
Ctn Weight: 14.5kg  
Barcode 9326548502129



**950W 75MM BELT SANDER**



Model No. 150-76-50075 **Adjusting Sanding Paper Knob**

Input power: 950W  
V/F: 240V-50Hz  
Belt speed: 120-380m/min  
Belt size: 75\*533mm  
Soft grip  
Dust collection system  
Ctn Qty.: 2Pcs  
Ctn Size: 39x36x44cm  
Ctn Weight: 16kgs  
Accessories: 1pc collection bag  
Barcode 9326548500750



**Dust Collection system**



## 200W MULTI-TOOL

Model No.150-84-50229

Input power:200W  
 V/F:230V/50Hz  
 Oscillations:8000-22000rpm  
 Oscillation Angle: 2.8 degrees  
 Universal type blades  
 Ctn Qty.: 5Pcs  
 Ctn Size: 54x38x22cm  
 Ctn Weight: 12kgs

Barcode 9326548502297

variable speed control  
 toolbag for accessories



\*Accessories:

82mm grinding pad, 3pcs sanding paper for wood, 3pcs sanding paper for metal, fixed scraper blade, stainless steel E-Cut saw blade narrow(30mm)- for wood, stainless steel E-Cut saw blade narrow(10mm)- for wood, B-metal E-Cut saw blade narrow(35mm)- for wood, B-metal E-Cut saw blade narrow(35mm)- for wood, HSS segment saw blade-for metal, Carbide segment saw blade, toolbag for accessories\*



## 130W 80PC STRAIGHT GRINDER

Model No.150-35-50009

Input power:130W  
 V/F:240V/50Hz  
 No load speed:0-30000RPM  
 Ctn Qty.: 4Pcs  
 Ctn Size: 36x31.5x19.5cm  
 Ctn Weight: 7.5kgs

With flexible shaft  
 Variable speed control

Accessories: Collets 2pcs, Cutting wheel 1pc, Cutting wheel adaptor 1pc, Sanding rubber 15pcs, Round sanding paper 24pcs, Wool wheel 2pcs, Grinding stone 1pc, Sanding roll 16pcs, cutting wheel fixture 1pc, screw drill 1pc, cone head grinding bit 1pc, Ball metal grinder bit 1pc, drill 2pcs, grinder bit 10pcs, collet spanner 1pc, L style wrench 1pc.

Barcode 9326548500095



Variable Speed



Flexible Shaft



## 130W STRAIGHT GRINDER 215PC KIT

Model No. 150-35-50108

Input power: 130W  
 240V/50Hz  
 No load speed: 0-30000RPM

Accessories: 34pcs sanding bands, 8pcs felt wheels, 1pc felt wheel point, 1pc cloth wheel, 1pc dress stone, 12pcs grinding wheels, 1pc flap wheel, 1pc wrench, 1pc diamond wheel, 5pcs fiberglass reinforced cut-off wheels, 1pc polishing compound, 36pcs cut-off wheels regular, 60pcs cut-off wheels heavy duty, 10pcs HSS twist drill bits, 3pcs HSS cutters, 2pcs sanding shanks, 7pcs diamond wheel points with 1/8" shank, 9pcs brushes, 4pcs collets chrome plated, 4pcs rubber emery wheels, 3pcs sanding disc wheels, 1pc screw mandrel for felt polishing, 4pcs silicon carbide grinding wheels, 3pcs rubber grinding wheels, 6pcs grinding wheels, 1pc electric rotary tool, 1pc flexible shaft.

Ctn Qty.: 2Pcs  
 Ctn Size: 48.5x27x38.5cm  
 Ctn Weight: 17.5kgs  
 Barcode 9326548501085



Variable Speed



Flexible Shaft



## 500W 100MM ANGLE GRINDER



Model No.150-35-50489

Input power: 500W  
 V/F: 240V/50Hz  
 No-load speed: 12000rpm  
 Disc size: 100mm  
 1pc grinding disc (AU standard) 100X6mm  
 Accessories: 1pc side handle, 1pc wrench  
 Barcode: 9326548504895



## 1200W 125MM ANGLE GRINDER



Model No.150-35-50012

Input power:1200W  
 230-240V 50Hz  
 No load speed:5000-12000RPM  
 Disc size:125mm  
 Ctn Qty.: 2Pcs  
 Ctn Size: 46x30x30cm  
 Ctn Weight: 13.5kgs  
 Aluminium alloy gear housing for durability and prolonged life  
 Ergonomic handle with soft grip for increased comfort  
 Spindle lock for easy disc replacement  
 Slim body design ensures a secure grip at all times  
 Two colour front handle  
 Accessories:1pc side handle, 1pc wrench, 1pc grinding disc  
 Barcode 9326548500125



125mm Grinding Disc



Variable Speed



Two Colour Front Handle



## ABRASIVE CUTTING WHEELS

Model No.150-13-48109

CUTTING DISC 100x1.0x16MM FLAT CENTRE (FOR METAL)  
 Barcode 9326548481097  
 Pack Qty: 25pcs



Model No.150-13-48324

CUTTING DISC 125x1.0x22MM FLAT CENTRE (FOR METAL)  
 Barcode 9326548483244  
 Pack Qty: 25pcs

Model No.150-13-48323

CUTTING DISC 115x1.0x22MM FLAT CENTRE (FOR METAL)  
 Barcode 9326548483237  
 Pack Qty: 25pcs

## 1200W POLISHER



Variable Speed Control



Auxiliary Handle

Model No.150-67-50349

Input power: 1200W  
V/F: 230V/50Hz  
No load speed: 600-3000RPM

Ctn Qty.: 4Pcs  
Ctn Size: 48x32x38cm  
Ctn Weight: 16.5kgs  
Backing pad: 180mm  
Barcode 9326548503492



1pc Bonnet



## 240MM ORBITAL POLISHER



Model No. 150-67-50201

Input power: 120W  
240V/50Hz  
No load speed: 3100rpm  
Powerful 120W motor helps maintain orbital rotation under load Random orbital action provides a swirl-free finish  
Accessories: Applicator pad 1pc, buffing pad 1pc  
Ctn Qty.: 4Pcs  
Ctn Size: 53x28x48cm  
Ctn Weight: 12kgs  
Barcode 9326548502013



## MITRE SAW STAND



Model No.150-76-50312

Product size: (118-198) X 63.2 X 90cm.  
Height extendable: 90-98.7cm.  
Double color painting  
Load capacity: 150KGS.  
Folding Heavy Duty Legs  
44mm Wide Rollers Supports  
Table base is adjustable to fitting different size table saw.  
The length and height is adjustable for log support.  
Ctn Qty.: 1Pcs  
Ctn Size: 124 x 27.5 x 20.5cm  
Ctn Weight: 15kg  
Barcode 9326548503126



## 350W JIGSAW



Dust Extraction Port

Model No.150-76-50350

Input power:350W  
V/F:230-240V/50Hz  
No load speed:3000S.P.M  
Cutting cap.:Wood: 55mm  
Steel: 6mm

Ctn Qty.: 6Pcs  
Ctn Size: 50x24x23.5cm  
Ctn Weight: 10.5kgs



1pc Saw Blade



Large European fitting blade

Accessories: 1pc saw blade, 1pc hexagon wrench

Barcode 9326548503508

## 800W RECIPROCATING SAW



Model No.150-76-50385

Input power:800W 230-240V 50Hz  
No load Speed:0-2800S.P.M  
Cutting capacity: Wood:105mm Steel:80mm  
Ctn Qty.: 4Pc

Ctn Size:49.5x38x20cm  
Ctn Weight:12kgs

Suit for cutting metal, wood and plastic.

Variable speed control

High Effective and durable reciprocating construction

Automatic locking for safety operation

Barcode 9326548503850



Variable Speed



Quick Change Blade

## 185MM CIRCULAR SAW 1200 WATTS



Angle Locking Knob

Model No. 150-76-50088

Input power: 1200W  
V/F:240V/50Hz  
No load speed: 5000RPM  
Max cutting depth: 90°/65mm 45°/43mm  
Blade size: 185mm X 20(Bore) X 24T  
Includes rip fence guide

Ctn Qty.: 2Pcs  
Ctn Size: 49x37x51cm  
Ctn Weight: 18kgs

Barcode 9326548500880



Lower Guard Lever





## 1200W ROUTER



Depth Adjustment



Variable Speed Control

Model No.150-75-50316

Input power: 1200W  
V/F:240V/50Hz  
No Load speed: 11500-30000RPM  
collet size :6.4mm



Spindle Lock

Variable speed control provides greater control on a variety of material  
Depth adjustment for precise control and accuracy  
Spindle lock for effortless bit changing  
Large soft handles ensure better grip and reduce operator's fatigue

Ctn Qty.: 2Pcs  
Ctn Size: 31x25x52cm  
Ctn Weight: 15kgs  
Barcode: 9326548503164



## 650W PLANER



Lock-off Button



Depth Adjustment

Model No.150-67-50315

Input power:650W  
V/F:240V/50Hz  
No load speed:16000RPM  
Planing Capacity: 82X2mm  
Ctn Qty.: 2Pcs  
Ctn Size: 37x32x37cm  
Ctn Weight: 13.7kgs  
Barcode: 9326548503157



## 1600W PAINT MIXER



Model No.150-67-50415

Input Power: 1600W  
Low Speed: 0-520RPM  
High Speed: 0-780RPM  
Mixer Bar: M14  
Two speed gear unit  
Barcode: 9326548504154



## 2000W HEAT GUN



**WARNING**  
**DROPPING HEAT GUN**  
**WHEN HOT WILL**  
**SMASH THE ELEMENT**

Model No.150-38-50014

Input power:2000W  
 V/F:240V/50Hz  
 Air temperature: 60°C-600°C  
 Air flow:200L/M-500L/M  
 Ctn Qty.: 5Pcs  
 Ctn Size: 50x32x58cm  
 Ctn Weight: 16kgs

Ergonomic handle with soft grip for increased comfort  
 Adjusting air temperature & air flow for different requirement  
 Accessories: flat nozzle, spoon reflector, shovel & cone nozzle  
 Barcode 9328548500149



Handle With Soft Grip



Adjusting Air Temperature & Air Flow



## 2000W INDUSTRIAL HEAT GUN



Model No.150-38-50230

Input power:2000W  
 V/F:240V/50Hz  
 Outlet temperature I: 50-600°C  
 II: 50-600°C  
 Air output I: 250L/min  
 II: 500L/min

SAA plug  
 LED indicator & temperature adjustable  
 flat nozzle, spoon reflector, shovel, cone nozzle & scraper  
 Ctn Qty.: 5Pcs  
 Ctn Size: 55x36x29cm  
 Ctn Weight: 11kgs  
 Barcode 9328548502303



Led Indicator & Temperature Adjustable



## 80W ELECTRIC SPRAY GUN



Model No. 150-78-50034

Input power: 80W  
 V/F:240V/50Hz  
 Flow rate: 280ml/min  
 Capacity: 800ml  
 Ctn Qty.: 3Pcs  
 Ctn Size: 62x27x26.5cm  
 Ctn Weight: 11kgs

Accessories: 1pc cleaning pin, 1pc viscosity cup, 1pc nozzle, 2pcs valves  
 Barcode 9328548500347



**1L BATTERY SPRAYER**

Model No. 150-78-44634

Working capacity: 1L  
3.0 volt  
2 x 1.5v AA batteries  
Working time: 90 minutes  
Working pressure: 1.8 bar  
Ctn QTY: 20  
Barcode 9337802017855



**5L LITHIUM GARDEN SPRAYER**

Model No. 150-78-44637

Working capacity: 5L  
Voltage: 3.7v  
Working pressure: 1.5 bar  
Working time: 150 minutes  
Charging time: 3 hours  
Ctn Qty: 8  
Barcode 9337802017945



**7.2V 5L LITHIUM SPRAYER**

Model No. 150-78-44635

Working capacity: 5L  
7.2v lithium battery  
Working time: 90 minutes  
Charging time: 3 hours  
Working pressure: 1.2 to 1.8 bar  
Ctn QTY: 6  
Barcode 9337802017682



**IN BUILT BATTERY & CHARGER**

**10.8V 16L LITHIUM SPRAYER**

Model No. 150-78-44636

Working capacity: 16L  
10.8v lithium battery  
3.5 hours continuous working time  
High performance diaphragm pump  
Telescopic metal lance  
Charging time: 3 hours  
Comfortable carrying strap  
Ctn QTY: 1  
Barcode 9337802017679



## 600W MINI BLOWER & INFLATOR



Model No.150-89-50235

Input power:600W  
230-240Vac 50Hz  
No load Speed:11000RPM  
3pc Inflator adaptors  
Ctn Qty.: 4Pcs  
Ctn Size: 40x27x36cm  
Ctn Weight: 9kgs

Barcode 9326548502358



## 2400W VACUUM BLOWER



Model No. 150-89-50298

Input power: 2400W  
V/F: 240V/50Hz  
No load speed: 14000RPM  
Max air speed: 270km/h  
Collection bag: 40L  
Ctn Qty.: 1Pc  
Ctn Size: 44.5x27x26.5cm  
Ctn Weight: 4.1kgs  
Shoulder strap  
Mulches 10 to 1  
Change from blower to vacuum conveniently  
Barcode 9326548502983



## 26CC PETROL BLOWER



Model No.150-89-50517

Displacement: 26CC  
 Engine: 2 stroke, air cooling  
 Max speed: 9000rpm  
 Fuel tank capacity: 480ml  
 Double crankshaft: 180km/h velocity  
 Anti vibration system  
 Extendable tube  
 Ctn Qty: 1pc  
 Ctn Size: 41x28x36cm  
 Ctn Weight: 5.8 kgs  
 Barcode 9326548505179

Meets new  
 Australian  
 emission  
 standards



## 500W GRASS TRIMMER



Model No.150-85-50389

Input power: 500W  
 V/F: 240V/50Hz  
 No load speed: 10500RPM  
 Cutting width: 280mm  
 Cutting line: 1.2mm  
 Ctn Qty.: 4Pcs  
 Ctn Size: 103.5x46x27cm  
 Ctn Weight: 12.5kgs  
 Bump feed system  
 Telescopic metal handle  
 Guide wheel for easy edge trimming  
 Soft grip handle for extra comfort  
 Adjustable secondary handle  
 Foot pad to release the handle until 60 degree  
 Barcode 9326548503898



## ROK REPLACEMENT SPOOL



Model No. 150-85-50407  
 Cut Line Spool to Suit 150-85-50389  
 Grass Trimmer  
 Barcode 9326548504079

## 25CC PETROL LINE TRIMMER



**NO SHORT CUTS  
 FULL LENGTH TO  
 SAVE YOUR BACK**

Model No. 150-85-50513

25CC  
 speed: 7500-8000RPM  
 two stroke  
 Ctn Qty.: 2Pcs  
 Ctn Size: 98x38.5x28cm  
 Ctn Weight: 14kgs  
 Accessories: 1pc support strap  
 1pc spark plug wrench

Barcode 9326548505137



Meets new  
 Australian  
 emission  
 standards

**33CC BRUSH CUTTER  
& LINE TRIMMER**

Model No. 150-85-50514

Power: 1.0kW  
Displacement: 33cm<sup>3</sup>  
Engine: 2 stroke/air cooling  
Start system: recoil start  
Engine max speed: 10,000 rpm  
Idling speed: 3,000rpm  
Clutch speed: 3,800rpm  
Fuel tank capacity: 960ml  
Fuel/oil ratio: 40:1  
Shaft length: front shaft: 760mm  
rear shaft: 680mm  
Front handle: J handle  
Ignition type: C.D.I.  
Carburetor type: diaphragm  
Aluminum pole: Dia. 1" (25.4mm)  
Single-shoulder harness with quick release  
Brushcutter 230mm Line Trimmer 440mm  
Barcode 9326548505144



**Meets new  
Australian  
emission  
standards**



**ROK REPLACEMENT SPOOL**



Model No. 150-85-50085

Cut Line Spool to suit  
150-85-50513 Line Trimmer  
Line Size: 2.0mm  
Barcode 9326548500859

**ROK REPLACEMENT SPOOL**



Model No. 150-85-50405

Cut Line Spool to suit 150-85-50514 Brush Cutter/Line Trimmer  
Barcode 9326548504055

**1800W CHAINSAW**



Model No. 150-76-50442

Engine: 1800w  
V/F: 240V 50Hz  
Bar: 16" 400mm  
Chain Speed: 13.5m/s  
Oil Tank Capacity: 150ml  
Automatic Chain Oiling  
SDS Quick Adjustment  
Oregon Chain & Bar  
Barcode 9326548504420



**300MM 25CC CHAINSAW**



Model No. 150-76-50506

Oregon Chain & Bar  
Output Power 0.9kw  
Max Engine Speed: 10000rpm  
Oil/fuel Mixing Ratio: 1:25  
Fuel Tank Capacity 260ml  
Oil tank capacity: 210ml  
Brake Time Lo.12s  
Supplied With Bottle,wrench,screwdriver  
Ctn Qty.: 2pcs  
Ctn Size: 51.5x28.5x25cm  
Ctn Weight: 10kgs  
Barcode 9326548505069



**Meets new  
Australian  
emission  
standards**

**400MM 46CC CHAINSAW**



Model No. 150-76-50507

Oregon Chain & Bar  
Output Power 1.8kw  
Max Engine Speed: 10000rpm  
Oil/fuel Mixing Ratio: 1:25  
Fuel Tank Capacity 550ml  
Oil tank capacity: 260ml  
Brake Time Lo.12s  
Supplied With Bottle,wrench,screwdriver  
Ctn Qty.: 2pcs  
Ctn Size: 47x28x40cm  
Ctn Weight: 2kgs  
Barcode 9326548505076



**Meets new  
Australian  
emission  
standards**

**450MM 53CC CHAINSAW**



Model No.150-76-50508

Oregon Chain & Bar  
Output Power: 2.2kw  
Max Engine Speed: 10000rpm  
Oil/Fuel Mixing Ratio: 1:25  
Fuel Tank Capacity: 550ml  
Oil Tank Capacity: 260ml  
Supplied with bottle, wrench, screwdriver  
Ctn Qty: 2pcs  
Ctn Size: 47x28 x40cm  
Ctn Weight: 15kg  
Barcode: 9326548505083



**Meets new  
Australian  
emission  
standards**

## SPARE PARTS LIST TO SUIT CHAINSAWS

No.	Description	Unit Price
8SP-50506-119	BAR COVER AND BRAKE ASSEMBLY	\$15.00
8SP-50506-152	CHAIN	\$17.40
8SP-50506-153	BAR	\$15.00
8SP-50506-20	SPARK PLUG	\$5.00
8SP-50506-24	IGNITION COIL	\$20.00
8SP-50507-105	IGNITION COIL	\$20.00
8SP-50507-124	BAR AND BRAKE COVER ASSEMBLY	\$20.00
8SP-50507-154	PULL START ASSEMBLY	\$20.00
8SP-50507-162	CHAIN	\$21.05
8SP-50507-163	BAR	\$15.00
8SP-50508-105	IGNITION COIL	\$20.00
8SP-50508-124	BAR AND BRAKE COVER ASSEMBLY	\$20.00
8SP-50508-154	PULL START ASSEMBLY	\$20.00
8SP-50508-162	CHAIN	\$25.00
8SP-50508-163	BAR	\$20.00
8SP-50508-84	SPARK PLUG	\$5.00

## 600W HEDGE TRIMMER



Model No. 150-85-50390

Input power: 600W  
 V/F: 230-240V/50Hz  
 No load speed: 1700SPM  
 Blade length: 510mm  
 Ctn Qty.: 4Pcs  
 Ctn Size: 94x31x25cm  
 Ctn Weight: 12.5kgs  
 Electric brake  
 Blade head protection  
 Barcode 9328548593904





## 33CC POLE CHAINSAW WITH EXTENSION



Model No. 150-76-50515

Power: 1.0kW  
 Displacement: 33cm<sup>3</sup>  
 Engine: 2 stroke/air cooling  
 Start system: recoil start  
 Engine max speed: 10,000 rpm  
 Idling speed: 3,000rpm  
 Clutch speed: 3,800rpm  
 Fuel tank capacity: 960ml  
 Fuel/oil ratio: 40:1  
 Shaft length: front shaft: 760mm  
 Rear shaft: 660mm  
 Front handle: J handle  
 Ignition type: C.D.I.  
 Carburetor type: diaphragm  
 Aluminum pole: Dia. 1" (25.4mm)  
 Single-shoulder harness with quick release  
 Cutting speed: 10 m/s  
 Oil tank capacity: 150ml  
 Chain: OREGON (91PD40X)  
 Chain pitch: 3/8"  
 Chain gauge: 0.05"  
 Bar length: 10" (254mm)  
 Bar: OREGON (541203)  
**Bonus Extension Pole**  
 Ctn Qty: 2  
 Ctn Size: 95.5 x 28.5 x 39.5cm  
 Ctn Weight: 20.5kg  
 Barcode 9328548505151



**Meets new  
 Australian  
 emission  
 standards**

## 33CC POLE HEDGE TRIMMER WITH EXTENSION



Model No. 150-85-50516

Power: 1.0kW  
 Displacement: 33cm<sup>3</sup>  
 Engine: 2 stroke/air cooling  
 Start system: recoil start  
 Engine max speed: 10,000 rpm  
 Idling speed: 3,000rpm  
 Clutch speed: 3,800rpm  
 Fuel tank capacity: 960ml  
 Fuel/oil ratio: 40:1  
 Shaft length: front shaft: 760mm  
 Rear shaft: 660mm  
 Front handle: J handle  
 Ignition type: C.D.I.  
 Carburetor type: diaphragm  
 Aluminum pole: Dia. 1" (25.4mm)  
 Single-shoulder harness with quick release  
 Cutting length: 390mm  
 Tooth space: 24mm  
 Thickness of the blade: 2mm  
 Adjustable hedge trimmer head  
**Bonus Extension Pole**  
 Ctn Qty: 2  
 Ctn Size: 95.5 x 28.5 x 39.5cm  
 Ctn Weight: 18kg  
 Barcode 9328548505168

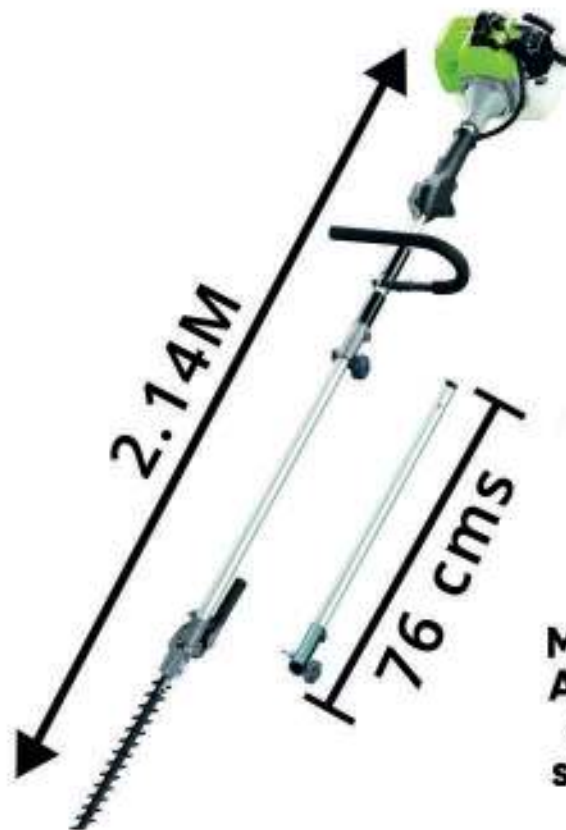

**Meets new  
 Australian  
 emission  
 standards**

## 4T LOG SPLITTER



Model No. 150-51-50255

Motor: 1500W electric motor  
Max log size;520mm(length)  
x250mm(diameter)  
Ram travel:390mm  
Max Capacity: 4T  
Suitable Oil for Log Splitter: Castrol  
Hyspin AWS22 or Castrol Hyspin AWH32  
Ctn Qty.: 1Pc  
Ctn Size: 100 x 28,5 x 46cm  
Ctn Weight: 44kgs

Barcode 9326548502556



**Seasonal  
March-July**

## 6T LOG SPLITTER



Model No.150-51-50365

Motor: 1500W Electric Motor  
No Load Speed: 2950RPM.  
Max Capacity: 6 TON.  
Split Diameter: 50-250MM.  
Split Length: 520MM,  
Ram Travel: 390MM,  
Hydraulic Oil Capacity: 2.8L  
Suitable Oil for Log Splitter: Castrol Hyspin AWS22  
or Castrol Hyspin AWH32  
With detachable stand

Barcode 9326548503652



**Seasonal  
March-July**

**52CC POST HOLE DIGGER**

Model No. 150-70-50511

Engine: 2 stroke air cooling  
Displacement: 52cc  
Engine power: 1.5kw  
Max engine speed: 8000/min  
Idling speed: 3000rpm  
Fuel tank capacity: 1.2 litres  
Auger bit diameter: 150mm & 200mm  
Auger bit length: 800mm  
Includes 150mm, 200mm augers & 300mm extension  
Ctn Qty: 1

Barcode 99326548505113



**Meets new  
Australian  
emission  
standards**

**2200W 355MM CUT OFF SAW**



Model No. 150-76-50355

Input power: 2200W  
240V/50Hz  
No-load speed: 3800RPM  
Disk size: 355mm  
Ctn Qty.: 1Pc  
Ctn Size: 55x34x46cm  
Ctn Weight: 21kgs  
Powerful 2200W Motor  
Safety disc guard  
355mm cutting disc  
Accessories: 2pcs hex key  
Barcode 9326548503553



Safety Disc Guard



355mm Cutting Disc



### 1.5HP AIR COMPRESSOR



Model No. 150-02-50222

24 litre tank capacity  
Oil lubricated  
Drive pump diameter: 42 x 1  
136 L/min free air delivery  
Ctn Qty: 1Pc  
Ctn Size: 59 x 28 x 61cm  
Ctn Weight: 22kg  
Barcode: 9326548502228



### 2HP AIR COMPRESSOR



Model No. 150-02-50243

40 litre tank capacity  
Oil lubricated  
Drive pump diameter: 48 x 1  
206 L/min free air delivery  
Ctn Qty: 1Pc  
Ctn Size: 73.5 x 30 x 66cm  
Ctn Weight: 30kg  
Barcode: 9326548502433



### 10M AIR HOSE WITH NITTO TYPE FITTINGS

Model No. 150-02-50518

Length: 10 metres  
Hose material: PVC  
Hose diameter: 8mm/12mm  
Working/Burst pressure: 8/24 bar  
Working temperature: -5 to 45 degrees celsius  
Hose fitted with Nitto style fittings  
Ctn Qty: 8  
Barcode: 9326548505182

### 20M AIR HOSE WITH NITTO TYPE FITTINGS

Model No. 150-02-50519

Length: 20 metres  
Hose material: PVC  
Hose diameter: 8mm/12mm  
Working/Burst pressure: 8/24 bar  
Working temperature: -5 to 45 degrees celsius  
Hose fitted with Nitto style fittings  
Ctn Qty: 8  
Barcode: 9326548505199

### 30M AIR HOSE WITH NITTO TYPE FITTINGS

Model No. 150-02-50520

Length: 30 metres  
Hose material: PVC  
Hose diameter: 8mm/12mm  
Working/Burst pressure: 8/24 bar  
Working temperature: -5 to 45 degrees celsius  
Hose fitted with Nitto style fittings  
Ctn Qty: 4  
Barcode: 9326548505205



## 100MM AIR DUSTER



Model No. 150-02-13971

100mm  
Easy trigger action  
Ideal to clean dirt & grime from machinery,  
engines & heavy equipment  
Ctn QTY: 40  
Barcode 9326548139714



## 250MM AIR DUSTER



Model No. 150-02-13972

250mm  
Easy trigger action  
Ideal to clean dirt & grime from machinery,  
engines & heavy equipment  
Ctn QTY: 40  
Barcode 9326548139721



## QUICK CHANGE BLOW GUN KIT



Model No. 150-02-13973

Pack includes:  
Blow gun with stubby nozzle  
55, 100 & 140mm extension nozzles  
Rubber tipped nozzle  
Ctn QTY: 72  
Barcode 9326548139738



## 5PC NITTO STYLE FITTINGS



Model No. 150-02-13974

Nitto style fittings  
Material: steel  
Size: 1/4" NPT SAE  
Ctn Qty: 100  
Barcode 9326548139745



## 5 SPEED BENCH DRILL PRESS



Magnetic Switch



13mm Drilling Capacity

Model No. 150-19-51967

Input power: 250W  
230V/50Hz  
13mm Chuck  
Table size: 160x160mm  
Base size: 314x200mm  
Overall height: 580mm  
Ctn Qty.: 1Pc  
Ctn Size: 44x34x22cm  
Ctn Weight: 16kgs  
Barcode: 9326548519677



## 12 SPEED INDUSTRIAL BENCH DRILL PRESS



Magnetic Switch with  
Emergency Stop



16mm Drilling Capacity



With Rack & Pinion

Model No. 150-19-51968

Input power: 550W  
230V/50Hz  
2MT  
16mm Chuck  
Table size: 260x260mm  
Base size: 240x410mm  
Overall height: 990mm  
Includes eye shield  
Ctn Qty.: 1Pc  
Ctn Size: 80x49x27.5cm  
Ctn Weight: 50kgs  
Barcode: 9326548519684



## 12 SPEED INDUSTRIAL PEDESTAL DRILL PRESS



Magnetic Switch with  
Emergency Stop



16mm Drilling Capacity



With Rack & Pinion

Model No. 150-19-51969

Input power: 550W  
2MT  
230V/50Hz  
16mm Chuck  
Table size: 260x260mm  
Base size: 240x410mm  
Overall height: 1570mm  
Includes eye shield  
Ctn Qty.: 1Pc  
Ctn Size: 114.5x46.5x27cm  
Ctn Weight: 55kgs  
Barcode: 9326548519691



**ROK CEMENT MIXER**



**2.2CU/FT**

**Model No. 150-12-51218**

2.2cuft Electric Cement Mixer  
Wet Load: 2.2cuft  
Dry Mix: 3cuft  
Gross Drum: 4cuft  
One Piece Bowl  
Pneumatic Wheel  
450w Motor  
Ctn Qty: 1pc  
Ctn Size: 75 X 65.5 X 70cm  
Ctn Weight: 65kg  
Unassembled  
Barcode 9328548512180



**CEMENT MIXER 180L/3.5CF 750W**



**Model No.150-12-51217**

Drum Capacity:180l/3.5cuft  
Power:750w Electric Motor  
Drum Mouth:450mm  
Drum Diameter:730mm  
Drum Height:680mm  
400-8 Pneumatic Tires  
Trade Quality. Unassembled. One Piece Bowl  
Ctn Qty: 1  
Ctn Size: 109 X 81 X 75cm  
Ctn Weight: 101kg  
Barcode 9328548512173



**300MM BOX FAN**



**Model No. 150-23-52356**

Power: 50w  
V/F: 240/50Hz  
Fan size: 300mm  
Blade: 5 x PP blades  
3 speed settings  
360 degree rotary louver  
White & black panel  
Ctn Qty: 1

Barcode 9326548523568



**Seasonal  
August-March**

**300MM 24V CORDLESS FAN**



**Model No. 150-23-52357**

Power: 20w  
V/F: 24V DC  
Fan size: 300mm  
Blade: 3pc aluminium  
Variable speed settings  
Brushless DC motor, long lasting up to  
15000hrs  
Battery: 15600mAh  
Charge time: 3-5 hours  
Running time: 4-8 hours (highest speed)  
Rechargeable function USB socket  
Tilt adjustable  
Ctn Qty: 1

Barcode 9326548523575



**Seasonal  
August-March**



## 500MM TURBO FLOOR FAN



Model No.150-23-52349

Input power: 90W  
Colour: black  
Three Speed Settings  
5 x PP plastic fan blades  
Full plastic housing  
Tilt adjustment  
Ctn Qty: 1pc  
Barcode 9326548523490



**Seasonal  
August-March**

## 400MM METAL FLOOR FAN



Model No.150-23-52348

Input power: 90W  
Copper finish  
Three Speed Settings  
Tilt adjustment  
Max adjustment: 120 degrees  
All metal construction  
3pc Aluminium fan blade  
"U" shape metal base  
Ctn Qty: 1pc  
Ctn Size: 51x20x51cm  
Barcode 9326548523483



**Seasonal  
August-March**

## 400MM METAL PEDESTAL FAN



Model No.150-23-52346

Input power: 50W  
Copper finish  
Three speed settings  
Height adjustable  
Max height: 120cm  
All metal construction  
4pc Aluminium fan blade  
Oscillation  
Ctn Qty: 1pc  
Ctn Size: 46x17x59cm  
Barcode 9326548523469



**Seasonal  
August-March**

## 400MM METAL DESK FAN



Model No. 150-23-52328

ROK  
400mm Metal Desk Fan  
50 watts  
3 Speed Settings  
Oscillation  
Height Adjustable  
4pc Fan Blade  
Chrome finish  
Ctn Qty: 1  
Ctn Size: 47 x 28.5 x 48.5cm  
Ctn Weight: 5.5kg  
Barcode 9326548523285



**Seasonal  
August-March**

## 450MM FLOOR FAN



Model No. 150-23-52335

ROK  
450mm Metal Floor Fan  
100 watts  
3 Speed Settings  
Tilt Adjustable  
Metal Fan Blade  
Chrome Finish  
Ctn Qty: 1  
Ctn Size: 57 x 20 x 56cm  
Ctn Weight: 6.35kg  
Barcode 9326548523353



**Seasonal  
August-March**

## 450MM METAL WALL FAN



Model No. 150-23-52333

ROK  
450mm Metal Wall Fan  
60 watts  
3 Speed Settings with Pull Cord  
Oscillation  
4pc Fan Blade  
Chrome finish  
Ctn Qty: 1  
Ctn Size: 51.5 x 17 x 64cm  
Ctn Weight: 5.5kg  
Barcode 9326548523339



**Seasonal  
August-March**

## 450MM METAL PEDESTAL FAN



Model No. 150-23-52334

ROK  
450mm Metal Pedestal Fan  
60 watts  
3 Speed Settings  
Oscillation  
Height Adjustable  
4pc Fan Blade  
Chrome finish  
Ctn Qty: 1  
Ctn Size: 51 x 16 x 64cm  
Ctn Weight: 7.8kg  
Barcode 9326548523346



**Seasonal  
August-March**

## 450MM OSCILLATING FLOOR FAN



Model No. 150-23-52355

ROK  
450mm Oscillating Floor Fan  
90 watts  
3 Speed Settings  
3 Aluminium Blades  
Full Copper Motor  
70 Degree Oscillating Head  
Stable U Shape Base  
Ctn Qty: 1

Barcode 9326548523551



**Seasonal  
August-March**

## 450MM FLOOR FAN



Model No. 150-23-52309

ROK  
FAN FLOOR SWIVEL HEAD 450MM  
130 Watt Motor  
3 SPEEDS  
Ctn Qty: 1Pc  
Ctn Size: 56.5x20x56cm  
Ctn Weight: 6.35kgs  
Barcode 9326548523094



**INDUSTRIAL SERIES**

## 450MM PEDESTAL FAN



Model No. 150-23-52317

ROK  
FAN INDUSTRIAL PORTABLE 450MM  
100 Watt Motor  
Oscillating Head  
3 SPEEDS  
Ctn Qty: 1Pcs  
Ctn Size: 64.5x17x51.5cm  
Ctn Weight: 13.5kgs  
Barcode: 9326548523179



**INDUSTRIAL SERIES**

## 750MM WALL FAN



Model No. 150-23-52315

ROK 750MM  
FAN INDUSTRIAL WALL MOUNT  
200 Watt Motor  
Oscillating Head  
3 SPEEDS  
Ctn Qty: 1Pc  
Ctn Size: 82x20x82cm  
Ctn Weight: 26kgs  
Barcode: 9326548523155



**INDUSTRIAL SERIES**

## 750MM FLOOR FAN



Model No. 150-23-52310

ROK  
FAN INDUSTRIAL PEDESTAL 750MM  
200 Watt Motor  
Oscillating Head  
3 SPEEDS  
Ctn Qty: 1Pc  
Ctn Size: 82x20x82cm  
Ctn Weight: 26kgs  
Barcode: 9326548523100



**INDUSTRIAL SERIES**

**280W 750MM WALL FAN**



**Model No.150-23-52316**

Input power: 280W copper motor  
90 degree oscillating head  
Wall mounting bracket  
Three metal blade fan  
Three speed settings  
Adjustable tilt angle  
High capacity fan moves large amounts of air  
Ctn Qty: 1pc  
Ctn Size: 81x81.2x18.2cm  
Ctn Weight: 26kg  
Barcode 9326548523162



**Seasonal  
August-March**

**280W 750MM PEDESTAL FAN**



**Model No.150-23-52311**

Input power: 280W copper motor  
90 degree oscillating head  
Heavy base for stability  
Three metal blade fan  
Three speed settings  
Adjustable tilt angle  
High capacity fan moves large amounts of air  
Ctn Qty: 1pc  
Ctn Size: 81x81.2x18.2cm  
Ctn Weight: 26kg  
Barcode 9326548523117



**Seasonal  
August-March**

**230W 650MM MIST FAN**



**Model No.150-23-52351**

Input power: 230W copper motor  
Water tank capacity: 20 litres  
Continuance water supply: 6 hours  
Diameter: 26 inch/650mm  
Height: 1700mm  
90 degree oscillation  
Three speeds  
Close net guards with heavy base  
Square pillar with water recycle  
Barcode 9326548523513



**Seasonal  
August-March**



**built**



**HAND TOOLS**



# built

## HAND TOOLS

### Introduction

Electaserv has over 40 years experience in the hand tool category providing extensive ranges to the national market during this time.

“Built” Hand tools were launched in 2012, the range has been developed from years of experience in monitoring top-moving lines in various markets.

This knowledge has enabled us to best develop a hand tool range that not only achieves our required quality standard and price but also cuts through the market with a branding that is easily identified and appealing to the consumer.

Our research indicates that consumers make a connection through the following.

- Built Hand tools – Building, Timber, Trade, Strength, Stability, Solid, Established.

The packaging of each product has taken into account both required product information and the need to optimize hanging space in store.

Further information can be found on our website at [www.electaserv.com.au](http://www.electaserv.com.au)



## HAMMERS/SPUD BAR

Barcode	Product No.	Description	Pack Qty	Price
	190-36-05006	560G 20OZ CLAW HAMMER	6	
<b>•FIBREGLASS HANDLE •DROP FORGED</b>				



Barcode	Product No.	Description	Pack Qty	Price
	190-36-05036	560G 20OZ CLAW HAMMER	6	
<b>•20OZ •METAL HANDLE •DROP FORGED •SOFT GRIP</b>				



Barcode	Product No.	Description	Pack Qty	Price
	190-36-05582	1.1KG CLUB HAMMER	6	
	190-36-05584	1.8KG CLUB HAMMER	6	
<b>•DROP FORGED •FIBREGLASS HANDLE</b>				



Barcode	Product No.	Description	Pack Qty	Price
	190-36-05603	1.8KG 4LB SLEDGE HAMMER	6	
<b>•4 LB •350MM FIBREGLASS HANDLE •DROP FORGED</b>				



Barcode	Product No.	Description	Pack Qty	Price
	190-36-05606	2.7KG 6LB SLEDGE HAMMER	6	
	190-36-05608	3.6KG 8LB SLEDGE HAMMER	6	
	190-36-05610	4.5KG 10LB SLEDGE HAMMER	4	
	190-36-05612	5.4KG 12LB SLEDGE HAMMER	4	
<b>•FIBREGLASS HANDLE •DROP FORGED</b>				



Barcode	Product No.	Description	Pack Qty	Price
	190-16-17897	SPUD BAR	4	
<b>•1.8 M X 25MM •ONE END CHISEL &amp; ONE END ROUND SPUD •ROUND BAR</b>				



ROUND SPUD END



CHISEL END



## PLIERS/SAWS

Barcode	Product No.	Description	Pack Qty	Price	Barcode	Product No.	Description	Pack Qty	Price
	190-69-15302	250MM MULTIGRIP PLIER	6			190-69-15318	200MM LONG NOSE PLIER	12	

	190-69-15216	400MM MULTIGRIP PLIER	4			190-69-15307	200MM DIAGONAL PLIER	12	
----------------------------------------------------------------------------------	--------------	-----------------------	---	--	-----------------------------------------------------------------------------------	--------------	----------------------	----	--

•HEAVY DUTY

	190-69-15328	200MM LINESMAN PLIER	12	
-----------------------------------------------------------------------------------	--------------	----------------------	----	--

•BUILT 200MM PROFESSIONAL SERIES •NICKEL PLATED  
•HARDENED CUTTING EDGE COMFORTABLE CONTOURED HANDLE



Barcode	Product No.	Description	Pack Qty	Price
	190-69-17310	250MM VICE LOCKING PLIER	6	

•HEAVY DUTY CARBON STEEL •HARDENED STEEL JAWS



Barcode	Product No.	Description	Pack Qty	Price
	190-69-15630	250MM FENCING PLIERS	5	

	190-69-15632	300MM FENCING PLIER	5	
------------------------------------------------------------------------------------	--------------	---------------------	---	--

•FULLY DROP FORGED HARD PRECISION JAWS •HEAVY DUTY



Barcode	Product No.	Description	Pack Qty	Price
	190-76-21915	HACKSAW	6	

•SWEDISH PATTERN •HEAVY DUTY •ADJUSTABLE CUTTING ANGLE TO 45 AND 90 DEGREES



Barcode	Product No.	Description	Pack Qty	Price
	190-76-22218	HANDSAW	10	

•450MM •TRI COLOUR PLASTIC HANDLE •65MN HEAT TREATED SAW BLADE •AGGRESSIVE TEETH GROUND ON 3 EDGES FOR FAST AND PRECISION CUTTING. 8 TEETH PER INCH

Barcode	Product No.	Description	Pack Qty	Price
	190-76-22222	HANDSAW	10	

•560MM •TRI COLOUR PLASTIC HANDLE •65MN HEAT TREATED SAW BLADE •AGGRESSIVE TEETH GROUND ON 3 EDGES FOR FAST AND PRECISION CUTTING 8 TEETH PER INCH



## KNIVES/SOCKET & SPANNER SET/ADJUSTABLE WRENCH

Barcode	Product No.	Description	Pack Qty	Price
	190-47-08003	TRIMMING KNIFE	12	

• WTH RETRACTABLE BLADE



Barcode	Product No.	Description	Pack Qty	Price
	190-47-08037	SNAP OFF BLADE KNIFE	30	

•LARGE •HEAVY DUTY •METAL INSERT AND SOFT GRIP HANDLE



Barcode	Product No.	Description	Pack Qty	Price
	190-70-12076	12 PC HOLLOW PUNCH SET	5	

•METRIC: 3, 4, 5, 6, 7, 8, 10, 11, 12, 14, 16, 19MM



Barcode	Product No.	Description	Pack Qty	Price
	190-70-12077	10PC WAD PUNCH SET	5	

•SIZES: 5, 6, 8, 10, 12.5, 16, 20, 25, 32MM •HEAT TREATED CARBON STEEL CONSTRUCTION •PRECISION GROUND FLUTES AND CUTTING EDGES



Barcode	Product No.	Description	Pack Qty	Price
	190-78-16140	ANGLE GRINDER SPANNER	12	

•ADJUSTABLE •2 PIN



Barcode	Product No.	Description	Pack Qty	Price
	190-78-06311	27PC SOCKET SET SAE & METRIC	1	

•27 PIECE •3/4INCH DRIVE •SAE & METRIC •7/8 - 2 SAE •22-50MM



Barcode	Product No.	Description	Pack Qty	Price
	190-78-16180	COMBINATION SPANNER SET	6	

•22 PIECE •SAE & METRIC •1/4 - 3/4 SAE •6-19MM



Barcode	Product No.	Description	Pack Qty	Price
	190-94-17603	200MM ADJUSTABLE WRENCH	6	

Barcode	Product No.	Description	Pack Qty	Price
	190-94-17604	250MM ADJUSTABLE WRENCH	6	

Barcode	Product No.	Description	Pack Qty	Price
	190-94-17605	300MM ADJUSTABLE WRENCH	6	

•CHROME PLATED • HALF DOUBLE BLISTER PACKAGING



## CLAMPS/MEASURING/BRUSHES

Barcode	Product No.	Description	Pack Qty	Price
	190-13-08503	QUICK ACTION CLAMP	5	

• 200MM X 80MM • 2 PIECE • F TYPE CLAMP COMFORT GRIP HANDLE



Barcode	Product No.	Description	Pack Qty	Price
	190-13-08578	25LB MAGNETIC WELDING CLAMP	6	

	190-13-08579	50LB MAGNETIC WELDING CLAMP	6	
-----------------------------------------------------------------------------------	--------------	-----------------------------	---	--

	190-13-08581	75LB MAGNETIC WELDING CLAMP	6	
-----------------------------------------------------------------------------------	--------------	-----------------------------	---	--

•MAGNETIC • HOLDS METAL OBJECTS AT 45, 90 & 135 DEGREES •IDEAL FOR METAL WORKING, WELDING AND FABRICATION APPLICATIONS



Barcode	Product No.	Description	Pack Qty	Price
	190-81-07207	8M TAPE MEASURE	12	

	190-81-07208	8M 26FT TAPE MEASURE	12	
------------------------------------------------------------------------------------	--------------	----------------------	----	--

•SHOCK RESISTANT •25MM BLADE •12 PCE DISPLAY BOX



Barcode	Product No.	Description	Pack Qty	Price
	190-81-07493	100M / 330FT MEASURING TAPE	5	

•FIBREGLASS •OPEN REEL



Barcode	Product No.	Description	Pack Qty	Price
	190-10-09297	WIRE BRUSH SET	12	

•3 PIECE •STAINLESS STEEL, NYLON & BRASS



Barcode	Product No.	Description	Pack Qty	Price
	190-10-09332	STAINLESS STEEL BRUSH	12	

•4 ROW •STAINLESS STEEL •PLASTIC HANDLE



## PAINTING ACCESSORIES/DRILL SETS

Barcode	Product No.	Description	Pack Qty.	Price
	190-52-20510	5 PCE MEASURING JUG SET	4	
<b>•250ML, 500ML, 1L, 2L &amp; 5L •5 PIECE</b>				

Barcode	Product No.	Description	Pack Qty.	Price
	190-11-14000	SKELETON CAULKING GUN	24	
<b>•230MM •SKELETON •FRICTION DRIVE</b>				



**FOOD GRADE MATERIAL**



Barcode	Product No.	Description	Pack Qty.	Price
	190-67-09225	PAINT ROLLER KIT	17	
<b>•230MM</b>				

Barcode	Product No.	Description	Pack Qty.	Price
	190-67-09229	365 X 60MM PAINT MIXER - SUIT 4L TINS	10	
	190-67-09230	422 X 85MM PAINT MIXER - SUIT 10L TINS	10	
	190-67-09227	600MM X 100MM PAINT MIXER - SUIT 20L TINS	10	
<b>•QUICKLY MIX SMALL BATCHES OF PAINT, MORTAR, GROUT OR CONCRETE</b>				



Barcode	Product No.	Description	Pack Qty.	Price
	190-19-13821	21 PCE 1/16 - 3/8" H.S.S. DRILL SET	10	
	190-19-13829	29 PCE 1/16 - 1/2" H.S.S. DRILL SET	3	
<b>•HIGH SPEED STEEL • METAL CASE</b>				

Barcode	Product No.	Description	Pack Qty.	Price
	190-19-13846	25 PCE 1-13MM H.S.S. DRILL SET	5	
	190-19-13839	29 PCE 1/16 - 1/2" H.S.S. DRILL SET	5	
<b>•TITANIUM COAT •METAL CASE</b>				



**POWER TOOL ACCESSORIES**

Barcode	Product No.	Description	Pack Qty	Price
	190-16-13834	COUNTERSINK BIT SET	10	

•3 PIECE • 12, 16 & 19MM •ALLOY STEEL •PRECISION MACHINED AND HEAT TREATED HIGH CARBON ALLOY BITS



Barcode	Product No.	Description	Pack Qty	Price
	190-10-09545	75MM TWIST KNOT WIRE BRUSH	10	

• 75MM TWIST KNOT WIRE BRUSH • WITH MULTI FIT THREAD •14MM X 2MM THREAD WITH MULTI FIT ADAPTORS 10MM X 1.25 & 10MM X 1.5



Barcode	Product No.	Description	Pack Qty	Price
	190-19-13835	STEP DRILL 6-20MM	5	

Barcode	Product No.	Description	Pack Qty	Price
	190-19-13843	STEP DRILL 6-30MM	10	

•TITANIUM COATED •HIGH SPEED STEEL



Barcode	Product No.	Description	Pack Qty	Price
	190-19-13838	3 PIECE STEP DRILL SET IN ALUMINIUM CASE	10	

•DROP FORGED HEAT TREATED HIGH SPEED STEEL WITH TITANIUM COATING •6 STEP BIT: 3/16"- 1/2" •9 STEP BIT: 1/4"- 3/4" •13 STEP BIT: 1/8"-1/2"



Barcode	Product No.	Description	Pack Qty	Price
	190-19-13862	6-40MM TITANIUM COATED HSS	25	

•TITANIUM COATED. HIGH SPEED STEEL. STRAIGHT FLUTE



Barcode	Product No.	Description	Pack Qty	Price
	190-19-13864	STEP DRILL 6-20MM HSS STEEL	10	

•HIGH SPEED STEEL •SPIRAL FLUTE •3/4" HEX SHANK



Barcode	Product No.	Description	Pack Qty	Price
	190-19-13865	STEP DRILL 6-30MM HSS STEEL	10	

•HIGH SPEED STEEL •SPIRAL FLUTE •3/4" HEX SHANK



Barcode	Product No.	Description	Pack Qty	Price
	190-19-13866	STEP DRILL 6-40MM HSS STEEL	10	

•HIGH SPEED STEEL. SPIRAL FLUTE



## SCREWDRIVERS/TOOL KIT

Barcode	Product No.	Description	Pack Qty	Price	Barcode	Product No.	Description	Pack Qty	Price
	190-08-02553	POWER SCREWDRIVER ADAPTOR SET	6			190-62-02903	NUTDRIVER PWR SCREWDRIVER SET	6	

•3 PIECE •TAKES 1/4, 3/8, 1/2 INCH DRIVE SOCKETS •SUITS POWER SCREWDRIVERS AND CORDLESS DRILLS •TRIPLE CHROME PLATED •HIGH VISIBILITY MARKINGS FOR EASIER & FASTER SOCKET SELECTION



•SIZES 6, 8, 10MM •FITS ALL POWER DRILLS, SCREW GUNS, CORDLESS AND MAGNETIC DRIVERS



Barcode	Product No.	Description	Pack Qty	Price	Barcode	Product No.	Description	Pack Qty	Price
	190-08-02535	33PC SECURITY BIT SET	6			190-77-01796	19PC SCREWDRIVER SET PLASTIC CASE:	10	

•COMMON SIZES •BLOW MOULD CASE •CONTENTS: 32PC CRV 25MM SECURITY BITS SIZES: TORQUE: 6, 8, 10MM; SPANNER: 4, 6, 8, 10MM; TRI-WING: #1, #2, #3, #4; HEX(MM): 2, 2.5, 3, 4, 5, 6MM; HEX(SAE): 5/32"



•19 PIECE •IN BLOW MOLD CASE

Barcode	Product No.	Description	Pack Qty	Price	Barcode	Product No.	Description	Pack Qty	Price
	190-84-98600	31PC HER TOOLS KIT	12			190-79-26612	PLASTIC STORAGE BOX	6	

•ADJUSTABLE COMPARTMENT INSERTS •SIZE: 455MM X 32 X 7.5CM •26 COMPARTMENTS



**Contents:**  
 1 x 165mm Long Nose Pliers  
 1 x 150mm Adjustable Wrench  
 1 x 230mm Torpedo Level  
 1 x 225g Claw Hammer  
 1 x 3.5m Tape Measure  
 1 x Large Snap Blade Knife  
 10 x Spare Knife Blades  
 1 x Multifunction Scissors  
 1 x Assorted Household Fasteners  
 1 x 6 Function Paint Scraper  
 1 x Screwdriver Handle  
 10 x 50mm Screwdriver Bits  
 1 x Soft Side Nylon Carrying Case

**AUTOMOTIVE**

Barcode	Product No.	Description	Pack Qty	Price
	190-11-91223	200MM X 5MM BLACK CABLE TIES 100PCE	30	
	190-11-91224	300MM X 5MM BLACK CABLE TIES 100PCE	10	
	190-11-91234	340MM HEAVY DUTY CABLE TIES X 50 PCE	30	
	190-11-91237	400MM X 10MM HEAVY DUTY CABLE TIES 50PCE	10	
<b>•UV RESISTANT NYLON</b>				



Barcode	Product No.	Description	Pack Qty	Price
	190-30-62581	PLASTIC FUNNEL	12	
<b>•200MM •FIXED PLASTIC</b>				



Barcode	Product No.	Description	Pack Qty	Price
	190-30-62582	FUNNEL SET	10	
<b>•3 PIECE •PLASTIC</b>				



Barcode	Product No.	Description	Pack Qty	Price
	190-30-62584	FUNNEL SET	12	
<b>•4 PIECE •PLASTIC •50, 75, 100 &amp; 120MM •DURABLE THICK WALLED FUNNEL</b>				



Barcode	Product No.	Description	Pack Qty	Price
	190-67-14551	PICK UP TOOL & REACHING AID	8	
<b>•804MM LONG •SUCTION CUP ENDS</b>				



## CHAIN/SUNDRY

Barcode	Product No.	Description	Pack Qty	Price	Barcode	Product No.	Description	Pack Qty	Price
---------	-------------	-------------	----------	-------	---------	-------------	-------------	----------	-------

	190-73-26009	RIVET GUN	6	
----------------------------------------------------------------------------------	--------------	-----------	---	--

- WITH 60 RIVETS • 4 NOZZLES • HEAVY DUTY • HANG PACK
- EASY TO USE RIVETER MAKES FAST PERMANENT JOINTS



Barcode	Product No.	Description	Pack Qty	Price
---------	-------------	-------------	----------	-------

	190-10-59991	BUTANE TORCH	6	
-----------------------------------------------------------------------------------	--------------	--------------	---	--

- PROFESSIONAL SERIES • AUTOMATIC IGNITION • MICRO TORCH DIRECTS A PINPOINT FLAME OF 13000C
- RUNNING TIME: 30 MINUTES • PUSH BUTTON IGNITION • CERAMIC TIP
- SAFETY LOCKING SYSTEM



Barcode	Product No.	Description	Pack Qty	Price
---------	-------------	-------------	----------	-------

	190-10-46299	CAN CRUSHER WITH BOTTLE OPENER	5	
------------------------------------------------------------------------------------	--------------	--------------------------------	---	--

- SUIT ALL 375ML CANS • INCLUDES WALL MOUNTING SCREWS • SOFT GRIP HANDLE



	190-11-20491	3MM X 130M WELDED CHAIN	1	
-----------------------------------------------------------------------------------	--------------	-------------------------	---	--

	190-11-20492	4MM X 80M WELDED CHAIN	1	
-----------------------------------------------------------------------------------	--------------	------------------------	---	--

	190-11-20493	5MM X 50M WELDED CHAIN	1	
-----------------------------------------------------------------------------------	--------------	------------------------	---	--

	190-11-20494	6MM X 31M WELDED CHAIN	1	
-----------------------------------------------------------------------------------	--------------	------------------------	---	--

	190-11-20495	8MM X 19M WELDED CHAIN	1	
-----------------------------------------------------------------------------------	--------------	------------------------	---	--

	190-11-20496	10MM X 12M WELDED CHAIN	1	
-----------------------------------------------------------------------------------	--------------	-------------------------	---	--

- 25KG DRUM • CARBON STEEL • RUST RESISTANT • HOT DIPPED GALVANISED • NOT RECOMMENDED FOR LIFTING



Barcode	Product No.	Description	Pack Qty	Price
---------	-------------	-------------	----------	-------

	190-23-20033	O RING ASSORTMENT	6	
-------------------------------------------------------------------------------------	--------------	-------------------	---	--





- 407 PIECE • METRIC • IN RE-USABLE PLASTIC STORAGE CASE
- COMMON SIZE O-RINGS FOR PLUMBING, AUTOMOTIVE AND GENERAL REPAIRS • COMPLETE WITH SECURE FIT LATCHED CASE





## EXTENSION LEADS

**HEAVY DUTY 15AMP LEAD WITH 10AMP PLUG**

Barcode	Product No.	Description	Pack Qty	Price
	190-52-59205	5M HD EXTENSION LEAD 15AMP LEAD / 10 AMP PLUG	8	
	190-52-59210	10M HD EXTENSION LEAD 15AMP LEAD / 10 AMP PLUG	8	
	190-52-59215	15M HD EXTENSION LEAD 15AMP LEAD / 10 AMP PLUG	8	
	190-52-59220	20M HD EXTENSION LEAD 15AMP LEAD / 10 AMP PLUG	8	
	190-52-59225	25M HD EXTENSION LEAD 15AMP LEAD / 10 AMP PLUG	4	
	190-52-59230	30M HD EXTENSION LEAD 15AMP LEAD / 10 AMP PLUG	4	



**HEAVY DUTY 15AMP LEAD WITH 15AMP PLUG**

	190-52-59235	15M HD EXTENSION LEAD 15AMP LEAD / 15 AMP PLUG	8	
	190-52-59239	25M HD EXTENSION LEAD 15AMP LEAD / 15 AMP PLUG	4	

• ASSORTED COLOURS



**HEAVY DUTY INSULATION**

Barcode	Product No.	Description	Pack Qty	Price
	190-52-59125	25M EXTENSION LEAD 10AMP LEAD/ 10AMP PLUG	8	



**4 SOCKET POWER BOARD**

Barcode	Product No.	Description	Pack Qty	Price
	190-52-59139	4 OUTLET POWER BOARD	48	

•4 SOCKETS WITH 4 SWITCHES, OVER CURRENT & SURGE PROTECTION



**6 SOCKET POWER BOARD**

Barcode	Product No.	Description	Pack Qty	Price
	190-52-59140	6 OUTLET POWER BOARD	48	

•6 SOCKETS WITH 6 SWITCHES, OVER CURRENT & SURGE PROTECTION



**DIGITAL MULTI-METER**

Barcode	Product No.	Description	Pack Qty	Price
	190-61-10282	DIGITAL MULTI-METER	12	

•LED DISPLAY •7 FUNCTIONS •19 RANGES •LOW BATTERY INDICATOR •OVERLOAD PROTECTION •1000 VOLT MAX •BATTERY INCLUDED



## HAND TRUCKS

Barcode	Product No.	Description	Pack Qty	Price	Barcode	Product No.	Description	Pack Qty	Price
	190-37-08612	130CM P HANDLE HAND TRUCK	1			190-37-08615	280KG P HANDLE HAND TRUCK	1	
<p>•250MM x 16MM BORE PNEUMATIC WHEELS •1300MM HIGH •180KG LOAD CAPACITY</p>					<p>•280KG LOAD CAPACITY HEIGHT: 1150MM 3.50-4 FLAT FREE WHEELS</p>				



**HEAVY DUTY  
FLAT FREE WHEELS**



Barcode	Product No.	Description	Pack Qty	Price	Barcode	Product No.	Description	Pack Qty	Price
	190-37-08616	HAND TRUCK HEAVY DUTY	1			190-37-08618	300KG TRADE HAND TRUCK	1	
<p>•330MM x 16MM BORE PNEUMATIC WHEELS •METAL RIM WHEELS •200KG LOAD CAPACITY •32MM TUBE</p>					<p>•330MM X 16MM BORE FLAT FREE WHEELS •WHEEL: 4.00-6 •300KG LOAD CAPACITY</p>				



**HEAVY DUTY**

**HEAVY DUTY  
FLAT FREE WHEELS**



## HAND TRUCKS

Barcode	Product No.	Description	Pack Qty	Price	Barcode	Product No.	Description	Pack Qty	Price
	190-37-08623	STAIR CLIMBER HAND TRUCK	1			190-37-08628	150KG PLATFORM TROLLEY	1	
<ul style="list-style-type: none"> <li>•LOAD RATING 180KGS •HEIGHT 1400MM</li> </ul>					<ul style="list-style-type: none"> <li>• 150KG LOAD CAPACITY • SIZE: 730 X 460 X 830MM</li> <li>• STEEL FRAME • HEAVY DUTY CASTORS • HANDLE FOLDS DOWN FLAT</li> </ul>				



**HEAVY DUTY**



Barcode	Product No.	Description	Pack Qty	Price	Barcode	Product No.	Description	Pack Qty	Price
	190-37-08629	300KG PLATFORM TROLLEY	1			190-93-08710	CHILDRENS WHEELBARROW	1	
<ul style="list-style-type: none"> <li>• 300KG LOAD CAPACITY • SIZE: 910 X 610 X 870MM</li> <li>• STEEL FRAME • HEAVY DUTY CASTORS • HANDLE FOLDS DOWN FLAT</li> </ul>					<ul style="list-style-type: none"> <li>•150MM SOLID WHEEL •UNASSEMBLED •PACKED IN SINGLE COLOUR BOX • WOODEN HANDLES</li> </ul>				



## WHEELBARROWS

Barcode	Product No.	Description	Pack Qty	Price	Barcode	Product No.	Description	Pack Qty	Price
	190-93-08707	60L WHEELBARROW	1			190-93-08768	80L WHEELBARROW	1	
<p>•60 LITRE CAPACITY •POLY TRAY •TYRE SIZE: (3.25 X 3.00-8) •WHEEL: STEEL RIM 16MM BORE •UNASSEMBLED</p>					<p>•80 LITRE CAPACITY •TRAY MATERIAL: GALVANISED STEEL •TYRE SIZE: (4.8 X 4.00-8) •WHEEL: STEEL RIM 16MM BORE •UNASSEMBLED</p>				



Barcode	Product No.	Description	Pack Qty	Price	Barcode	Product No.	Description	Pack Qty	Price
	190-93-08764	WHEELBARROW	1			190-93-08772	80L WHEELBARROW WITH POURER	1	
<p>•100 LITRE CAPACITY •POLY TRAY •16INCH X 4.00-8 PNEUMATIC TYRE •UNASSEMBLED</p>					<p>•80 LITRE CAPACITY •POLY TRAY WITH POURER FOR MORE ACCURATE DISPERSAL OF LOADS •TYRE SIZE: (16 X 6.5-8) •WHEEL: POLY RIM, 25MM BORE •UNASSEMBLED</p>				



## WHEELBARROWS

Barcode	Product No.	Description	Pack Qty	Price	Barcode	Product No.	Description	Pack Qty	Price
	190-93-08769	100L HD POLY TRAY WHEELBARROW	1			190-93-08771	100L HD METAL TRAY WHEELBARROW	1	
<p>•100 LITRE CAPACITY • POLY TRAY WITH REINFORCED EDGES •TYRE SIZE: (16 X 6.5-8) •WHEEL: STEEL RIM 25MM BORE •HEAVY DUTY TUBULAR STEEL FRAME •UNASSEMBLED</p>					<p>•100 LITRE CAPACITY •TRAY MATERIAL: POWDER COATED STEEL •TYRE SIZE: (16 X 6.5-8) •WHEEL: STEEL RIM 25.4MM BORE •HEAVY DUTY TUBULAR STEEL FRAME •UNASSEMBLED</p>				



Barcode	Product No.	Description	Pack Qty	Price	Barcode	Product No.	Description	Pack Qty	Price
	190-93-08762	100L POLY TRADE WHEELBARROW	1			190-93-08761	100L METAL TRADE WHEELBARROW	1	
<p>100 LITRE CAPACITY. POLY TRAY. FLAT FREE WHEEL. WHEEL SIZE 400 X 90MM. HEAVY DUTY FRAME CONSTRUCTION .UNASSEMBLED</p>					<p>100 LITRE CAPACITY. METAL TRAY. FLAT FREE WHEEL. WHEEL SIZE 400 X 150MM. HEAVY DUTY FRAME CONSTRUCTION .UNASSEMBLED</p>				

**FLAT FREE  
WHEEL**

**FLAT FREE  
WHEEL**



## WHEELS

Barcode	Product No.	Description	Pack Qty	Price	Barcode	Product No.	Description	Pack Qty	Price
	190-93-08611	250MM PNEUMATIC WHEEL	10			190-93-08705	330MM PNEUMATIC WHEEL	6	
<b>•250MM X 80MM X 16MM BORE</b>					<b>• 330MM X 80MM X 16MM BORE</b>				



Barcode	Product No.	Description	Pack Qty	Price	Barcode	Product No.	Description	Pack Qty	Price
	190-93-08715	400 X 90MM PNEUMATIC WHEEL	1			190-93-08722	400 X 135MM PNEUMATIC WHEEL	5	
<b>• 400 X 90MM X 25MM BORE</b>					<b>• 400 X 135MM X 25MM BORE</b>				



Barcode	Product No.	Description	Pack Qty	Price	Barcode	Product No.	Description	Pack Qty	Price
	190-93-08624	250MM 3.50-4 FLAT FREE WHEEL	6			190-93-08724	16 X 6.5-8 NO FLAT STEEL WHEEL	6	
<b>•STEEL RIM •200KG CAPACITY •16MM BORE</b>					<b>• 400 X 150MM X 25MM BORE. STEEL RIM</b>				



FLAT FREE



FLAT FREE

## WHEELS/TUBES

Barcode	Product No.	Description	Pack Qty	Price	Barcode	Product No.	Description	Pack Qty	Price
	190-93-08729	NO FLAT WHEEL 330MM X 80MM	6			190-93-08726	16 X 4.00-8 NO FLAT POLY WHEEL	6	
<b>•WHEEL SIZE: 330MM X 80MM X 16MM BORE. STEEL RIM</b>					<b>• 400 X 90MM X 25MM</b>				



**FLAT FREE**



**FLAT FREE**

Barcode	Product No.	Description	Pack Qty	Price	Barcode	Product No.	Description	Pack Qty	Price
	190-93-08727	16"X 4.00-8 NO FLAT STEEL WHEEL	6			190-93-08725	10X4.10/3.5-4 NO FLAT WHEEL	6	
<b>• 400 X 90MM X 25MM BORE. STEEL RIM</b>					<b>•250MM X 80MM X 16MM BORE</b>				



**FLAT FREE**



**FLAT FREE**

## WHEEL GUIDE

PRODUCT CODE	PRODUCT DESCRIPTION	TYPE	RIM	WHEELS TO SUIT		
				TIRE SIZE	BORE	WHEEL CODE
190-93-08612	280KG P HANDLE HAND TRUCK	Pneumatic	Steel	250mm x 80mm	16mm	190-93-08611
		Flat Free	Steel	250mm x 80mm	16mm	190-93-08614
		Flat Free	Steel	250mm x 80mm	16mm	190-93-08725
190-93-08616	HAND TRUCK HEAVY DUTY	Pneumatic	Steel	330mm x 80mm	16mm	190-93-08728
190-93-08611	280KG P HANDLE HAND TRUCK	Flat Free	Steel	250mm x 80mm	16mm	190-93-08725
		Flat Free	Steel	250mm x 80mm	16mm	190-93-08614
		Pneumatic	Steel	250mm x 80mm	16mm	190-93-08611
190-93-08618	200KG TRADE HAND TRUCK	Flat Free	Steel	330mm x 90mm	16mm	190-93-08728
190-93-08745	1 CUFT 85L DUMPING CART	Pneumatic	Steel	250mm x 80mm	16mm	190-93-08611
190-93-08750	200KG TRAILER	Pneumatic	Steel	380mm x 100mm	18mm	190-93-08730
190-93-08747	200KG DUMPING CART PUSH/TOW	Pneumatic	Steel	360mm x 100mm	20mm	190-93-08741
190-93-08742	5CUFT YARD CART	Pneumatic	Poly	350mm x 90mm	18mm	190-93-08732
190-93-08743	2028 x 521 GARDEN CART	Pneumatic	Metal	250mm x 80mm	16mm	190-93-08611
190-93-08764	POLY TRAY WHEELBARROW	Pneumatic	Poly	400mm x 95mm	25mm	190-93-08715
		Flat Free	Poly	400mm x 87mm	25mm	190-93-08726
		Flat Free	Steel	400mm x 95mm	25mm	190-93-08727
190-93-08700	WHEELBARROW POLY TRAY	Pneumatic	Poly	400mm x 150mm	25mm	190-93-08733
		Pneumatic	Steel	400mm x 115mm	25mm	190-93-08722
		Flat Free	Steel	400mm x 145mm	25mm	190-93-08724
190-93-08771	BUILDERS WHEELBARROW	Pneumatic	Steel	400mm x 115mm	25mm	190-93-08722
		Flat Free	Steel	400mm x 145mm	25mm	190-93-08724
190-93-08751	7CUFT METAL TRADE BARROW	Flat Free	Steel	400mm x 140mm	25mm	190-93-08724
		Pneumatic	Steel	400mm x 115mm	25mm	190-93-08722
190-93-08762	7CUFT POLY TRADE BARROW	Flat Free	Poly	400mm x 87mm	25mm	190-93-08726
		Flat Free	Steel	400mm x 95mm	25mm	190-93-08727
		Pneumatic	Poly	400mm x 95mm	25mm	190-93-08715

Barcode	Product No.	Description	Pack Qty	Price
	190-93-08609	10 INCH 3.5 - 4 TUBE TO SUIT 08611	10	
	190-93-08716	16 INCH 4.8/4.00-8 TUBE TO SUIT 08715	10	
	190-93-08721	16/6.5 - 8 WIDE TUBE TO SUIT 08722	10	



## PADLOCKS/GUN SAFES

Barcode	Product No.	Description	Pack Qty	Price
	190-66-21130	30MM BRASS PADLOCK	12	
	190-66-21140	40MM BRASS PADLOCK	6	
	190-66-21150	50MM BRASS PADLOCK	6	
	190-66-21160	60MM BRASS PADLOCK	6	

**•HEAVY DUTY •WITH 3 KEYS •HARDENED SHACKLE**



Barcode	Product No.	Description	Pack Qty	Price
	190-66-21340	40MM TWIN PACK PADLOCKS	12	
	190-66-21350	50MM TWIN PACK PADLOCKS	6	

**•WITH 3 KEYS •HARDENED SHACKLE**



Barcode	Product No.	Description	Pack Qty	Price
	190-76-21021	8 GUN ELECTRONIC GUN SAFE	1	

**•1450X400X300MM •3MM HOUSING •3MM DOOR  
•AMMUNITION BOX •KEY OVERRIDE •DIGITAL KEY PAD  
•5 LOCKING BOLTS**



Barcode	Product No.	Description	Pack Qty	Price
	190-66-21250	50MM LONG SHACKLE BRASS PADLOCK	12	

**•50MM •LONG SHACKLE •WITH 3 KEYS •HARDENED SHACKLE**



Barcode	Product No.	Description	Pack Qty	Price
	190-76-21020	5 GUN ELECTRONIC GUN SAFE	1	

**•1450X350X300MM •3MM HOUSING •3MM DOOR  
•AMMUNITION BOX •KEY OVERRIDE •DIGITAL KEY PAD  
•5 LOCKING BOLTS**



Barcode	Product No.	Description	Pack Qty	Price
	190-76-21022	12 GUN ELECTRONIC GUN SAFE	1	

**•1450X520X300MM •3MM HOUSING •3MM DOOR  
•AMMUNITION BOX •KEY OVERRIDE •DIGITAL KEY PAD  
•5 LOCKING BOLTS**





## ROPE

Barcode	Product No.	Description	Pack Qty	Price
	190-54-46109	100M BRICKLAYERS LINE	10	

•ASSORTED COLOURS •PLASTIC SPOOL •10PCS IN COLOUR DISPLAY BOX



Barcode	Product No.	Description	Pack Qty	Price
	190-74-46003	3MM X 60M PP ROPE ORANGE	20	

	190-74-46004	4MM X 30M PP ROPE WHITE	50	
----------------------------------------------------------------------------------	--------------	-------------------------	----	--

	190-74-46006	6MM X 15M PP ROPE GREEN	20	
------------------------------------------------------------------------------------	--------------	-------------------------	----	--

	190-74-46008	8MM X 15M PP ROPE RED	20	
------------------------------------------------------------------------------------	--------------	-----------------------	----	--

	190-74-46010	10MM X 10M PP ROPE BLUE	20	
------------------------------------------------------------------------------------	--------------	-------------------------	----	--

• SHRINK WRAPPED WITH LABEL





	190-74-46032	6MM X 40M BRAIDED COLOUR ROPE	12	
------------------------------------------------------------------------------------	--------------	-------------------------------	----	--

	190-74-46034	9MM X 30M BRAIDED COLOUR ROPE	12	
------------------------------------------------------------------------------------	--------------	-------------------------------	----	--

•BLUE, RED, YELLOW & GREEN •ASSORTED COLOURS



Barcode	Product No.	Description	Pack Qty	Price
	190-74-46017	6MM X 120M SILVER MONO POLY ROPE	6	

	190-74-46018	8MM X 100M SILVER MONO POLY ROPE	6	
-----------------------------------------------------------------------------------	--------------	----------------------------------	---	--

	190-74-46020	10MM X 100M SILVER MONO POLY ROPE	4	
-----------------------------------------------------------------------------------	--------------	-----------------------------------	---	--

•POLY BAGGED



Barcode	Product No.	Description	Pack Qty	Price
	190-74-46030	10MM X 125M SILVER MONO POLY ROPE	1	

	190-74-46031	12MM X 100M SILVER MONO POLY ROPE	1	
-------------------------------------------------------------------------------------	--------------	-----------------------------------	---	--

•ON SPOOL



Barcode	Product No.	Description	Pack Qty	Price
	190-84-11180	27 POCKET TOOL BAG	20	

•27 POCKET •HEAVY DUTY •450 X 250MM



## TIE DOWNS

Barcode	Product No.	Description	Pack Qty	Price
	190-71-64415	1PC 25MM X 4M 200KG RATCHET TIE DOWN STRAP	6	

•4 METRE X 25MM •200KG LOAD CAPACITY •QUICK AND EASY THUMB RELEASE WITH AUTOMATIC LOCK RATCHETING ACTION •WORKING CAPACITY: 250KGS



Meets Australian Standards AS/NZS 4380

Barcode	Product No.	Description	Pack Qty	Price
	190-71-64414	2PC 25MM X 4.5M 250KG RATCHET TIE DOWN STRAP	6	

Barcode	Product No.	Description	Pack Qty	Price
	190-71-64423	2PC 25MM X 5M RATCHET TIE DOWN	6	

•QUICK AND EASY THUMB RELEASE WITH AUTOMATIC LOCK RATCHETING ACTION



Meets Australian Standards AS/NZS 4380

Barcode	Product No.	Description	Pack Qty	Price
	190-71-64422	4PC 25MM X 4.5M 250KG RATCHET TIE DOWN	6	

•VINYL COATED, FORGED STEEL HOOKS FOR MAXIMUM STRENGTH •QUICK AND EASY THUMB RELEASE WITH AUTOMATIC LOCK RATCHETING ACTION



Meets Australian Standards AS/NZS 4380

Barcode	Product No.	Description	Pack Qty	Price
	190-82-91832	TRAILER CARGO NET 1.8M X 2.5M	5	

•HOLE SIZE: 50 X 50MM •16 HOOKS



Barcode	Product No.	Description	Pack Qty	Price
	190-71-64426	2PC 50MM X 5M RATCHET TIE DOWN RUBBER GRIPS	4	

•VINYL COATED, FORGED STEEL HOOKS FOR MAXIMUM STRENGTH •QUICK AND EASY THUMB RELEASE WITH AUTOMATIC LOCK RATCHETING ACTION •WORKING CAPACITY: 480KGS •



Meets Australian Standards AS/NZS 4380



## STORAGE CABINET/TAPE

Barcode	Product No.	Description	Pack Qty	Price
	160-13-40201	METAL STORAGE CUPBOARD	1	

•1800MM (H) X 900MM (W) X 400MM (D) •UNASSEMBLED  
•PICTURED ACCESSORIES NOT INCLUDED



Barcode	Product No.	Description	Pack Qty	Price
	160-13-40202	MESH DOOR STORAGE CABINET	1	

•1850MM (H) X 900MM (W) X 450MM (D) ASSEMBLY REQUIRED



Barcode	Product No.	Description	Pack Qty	Price
	190-81-07103	BARRIER TAPE	10	

•RED & WHITE STRIPES •100M x 75mm



Barcode	Product No.	Description	Pack Qty	Price
	190-81-07105	CAUTION TAPE	6	

•75MM X 100M



Barcode	Product No.	Description	Pack Qty	Price
	190-81-07101	SILVER JOINING TAPE (DUCT TAPE)	60	

•30M X 48MM •SILVER



Barcode	Product No.	Description	Pack Qty	Price
	190-81-07100	10M THREAD TAPE	24	

•10 METRE •THICKNESS 0.075MM



## WATER CONTAINERS

Barcode	Product No.	Description	Pack Qty	Price	Barcode	Product No.	Description	Pack Qty	Price
	180-10-00083	5L PLASTIC WATER CONTAINER	8			180-10-00084	15L PLASTIC WATER CONTAINER	8	

•MATERIAL: HDPE • CAPACITY: 5L • SIZE: 18.5(L) X 12(W) X 29(H)CM • SCREW LID WITH INNER CAP •BPA FREE SUITABLE FOR DRINKING WATER •FOOD & DRUG APPROVED MATERIAL

•MATERIAL: HDPE • CAPACITY: 15L • SIZE: 26(L) X 15(W) X 34.5(H)CM • SCREW LID WITH INNER CAP •BPA FREE SUITABLE FOR DRINKING WATER •FOOD & DRUG APPROVED MATERIAL

**FOOD  
GRADE  
MATERIAL**



**FOOD  
GRADE  
MATERIAL**



Barcode	Product No.	Description	Pack Qty	Price	Barcode	Product No.	Description	Pack Qty	Price
	180-10-00085	20L PLASTIC WATER CONTAINER	8			180-10-00086	30L PLASTIC WATER CONTAINER	8	

•MATERIAL: HDPE • CAPACITY: 20L • SIZE: 32(L) X 18.5(W) X 39.5(H)CM • SCREW LID WITH INNER CAP •BPA FREE SUITABLE FOR DRINKING WATER •FOOD & DRUG APPROVED MATERIAL

•MATERIAL: HDPE • CAPACITY: 30L • SIZE: 33.5(L) X 19(W) X 44(H)CM • SCREW LID WITH INNER CAP •BPA FREE SUITABLE FOR DRINKING WATER •FOOD & DRUG APPROVED MATERIAL

**FOOD  
GRADE  
MATERIAL**



**FOOD  
GRADE  
MATERIAL**



Barcode	Product No.	Description	Pack Qty	Price
	180-10-00087	10L WATER DRUM	8	

•MATERIAL: HDPE • CAPACITY: 10L • SIZE: 21(L) X 21(W) X 31.5(H)CM • SCREW LID WITH INNER CAP •BPA FREE SUITABLE FOR DRINKING WATER •FOOD & DRUG APPROVED MATERIAL

**FOOD  
GRADE  
MATERIAL**



Barcode	Product No.	Description	Pack Qty	Price	Barcode	Product No.	Description	Pack Qty	Price
	180-10-00121	30 LITRE PLASTIC DRUMS	9			180-10-00122	50 LITRE PLASTIC DRUMS	6	

•SIZE: 32 x 18.5 x 39.5CM •WEIGHT: 800G •SIDE HANDLES •SCREW CAP

•SIZE: 33.5 x 19 x 44CM •WEIGHT: 1550G •SCREW CAP •SIDE HANDLES

**FOOD  
GRADE  
MATERIAL**



**FOOD  
GRADE  
MATERIAL**





**GreenLeaf**

**GARDEN, RURAL  
& LEISURE**



# GreenLeaf

## GARDEN, RURAL & LEISURE

### Introduction

Electaserv has over 30 years experience in the garden tool market, providing extensive ranges over this period.

“Greenleaf” tools were launched in 2010, the range has been developed from years of experience in monitoring top-moving lines in various markets.

This knowledge has enabled us to best develop an Outdoor & Garden range that not only achieves our required quality standard and price but also cuts through the market with a branding that is easily identified and appealing to the consumer.

Our research indicates that consumers make a connection through the following.

- Greenleaf Garden & Leisure – Natural, Earthy, Outdoors, Nature, Peaceful, Energized.

The packaging of each product has taken into account both required product information and the need to optimize hanging space in store.

Further information can be found on our website at [www.electaserv.com.au](http://www.electaserv.com.au)





# GreenLeaf

GARDEN, RURAL & LEISURE

## COOLERS

Barcode	Product No.	Description	Pack Qty	Price	Barcode	Product No.	Description	Pack Qty	Price
	180-11-00161	2.5L COOLER	6			180-11-00163	6.5L ROUND COOLER WITH TAP	6	
<b>•PULL UP SPOUT •INSULATED WALL •Ø15 X H 26.5CMS</b>					<b>•INSULATED WALL • HOLD 8 CANS + ICE •Ø17.5 X H 33CMS</b>				



Barcode	Product No.	Description	Pack Qty	Price	Barcode	Product No.	Description	Pack Qty	Price
	180-11-00167	10L COOLER	5			180-11-00162	15L ROUND COOLER	1	
<b>•COMPACT SIZE FOR PICNICS •FLIP TOP LID •FOAM INSULATED •HOLDS 17 CANS •24 X 30 X 24.5CMS</b>					<b>•TAP WITH HANDLE •LOCKABLE LID •INSULATED WALL •HOLD 22 CANS + ICE •Ø35.5 X H 37CMS</b>				



Barcode	Product No.	Description	Pack Qty	Price	Barcode	Product No.	Description	Pack Qty	Price
	180-11-00164	25L COOLER	1			180-11-00165	50L COOLER	1	
<b>•SUITABLE FOR FISHING, CAMPING OR PICNICS • INDOOR &amp; OUTDOOR USE</b>					<b>•TRAVELING SIZE FOR OUTDOOR LIFE •FLIP TOP LID •FOAM INSULATED •HOLDS 96 CANS + ICE OR 10 2L</b>				



## POULTRY FEEDERS

Barcode	Product No.	Description	Pack Qty	Price	Barcode	Product No.	Description	Pack Qty	Price
	140-30-00305	2L STAINLESS STEEL POULTRY DRINKER	6			140-30-00314	4KG STAINLESS STEEL POULTRY FEEDER	6	
	140-30-00306	3L STAINLESS STEEL POULTRY DRINKER	6			140-30-00308	8KG STAINLESS STEEL POULTRY FEEDER	6	
	140-30-00307	9L STAINLESS STEEL POULTRY DRINKER	6			140-30-00309	10KG STAINLESS STEEL POULTRY FEEDER	6	
<p>•MANUFACTURED FROM STAINLESS STEEL 201 •HIGH QUALITY CONSTRUCTION •HANGING HANDLE</p>						140-30-00310	12KG STAINLESS STEEL POULTRY FEEDER	6	
						140-30-00311	15KG STAINLESS STEEL POULTRY FEEDER	6	



•MANUFACTURED FROM STAINLESS STEEL 201 •HIGH  
QUALITY CONSTRUCTION •HANGING HANDLE

Barcode	Product No.	Description	Pack Qty	Price
	140-30-00296	12KG AUTOMATIC CHICKEN FEEDER SIZE: 30.5 X 22.5 X 50CM	1	
	140-30-00297	20KG AUTOMATIC CHICKEN FEEDER SIZE: 47 X 22 X 50CM	1	



•MATERIAL: GALVANISED STEEL •RUST RESISTANT •ALLOWS  
CHICKENS TO FEED ON DEMAND •UNASSEMBLED

Barcode	Product No.	Description	Pack Qty	Price
	140-30-00261	45CM ANIMAL FEEDER	6	
	140-30-00262	60CM ANIMAL FEEDER	6	

•GALVANISED MATERIAL •HOOKS FITTED FOR EASY MOUNTING  
•HEAVY DUTY CONSTRUCTION







# GreenLeaf

GARDEN, RURAL & LEISURE

## ANIMAL TRAPS

Barcode	Product No.	Description	Pack Qty	Price
	190-03-48057	LIVE ANIMAL TRAP 450 X 125 X 125MM	1	
	190-03-48058	LIVE ANIMAL TRAP 600 X 175 X 175MM	1	
	190-03-48059	LIVE ANIMAL TRAP 820 X 300 X 250MM	1	

FULLY ASSEMBLED & READY TO USE • DURABLE & HEAVY DUTY GALVANISED CONSTRUCTION • HUMANE SOLUTION FOR RELOCATING ANIMALS



Barcode	Product No.	Description	Pack Qty	Price
	190-03-48065	LIVE ANIMAL TRAP 800 X 250 X 300MM	1	
	190-03-48066	LIVE ANIMAL TRAP 1060 X 380 X 430MM	1	

COLLAPSIBLE. FLAT PACKED. DURABLE & HEAVY DUTY GALVANISED CONSTRUCTION. HUMANE SOLUTION FOR RELOCATING ANIMALS .ASSEMBLY REQUIRED



Barcode	Product No.	Description	Pack Qty	Price
	Q-LA0242	WOODEN MOUSE TRAP SET 2	24	

•WOODEN BACKING •TWIN PACK •HANG SELL PACK

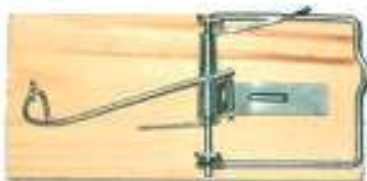

Barcode	Product No.	Description	Pack Qty	Price
	190-84-48044	THE BETTER MOUSE TRAP	10	

•CATCH AND RELEASE TRAP



Barcode	Product No.	Description	Pack Qty	Price
	190-84-48054	STANDARD TOP FUNNEL MOUSE TRAP 20.5 X 13 X 9CM	10	
	190-84-48053	JUMBO TOP FUNNEL MOUSE TRAP 30 X 15 X 15CM	6	

•STONG STEEL CONSTRUCTION • A HUMANE SOLUTION FOR RELOCATING RODENTS



Barcode	Product No.	Description	Pack Qty	Price
	Q-60669	LARGE RAT TRAP	48	

•WOODEN BACKING •170 X 80 X 10MM





# GreenLeaf

GARDEN, RURAL & LEISURE

## FLY TRAPS/MACHETE/CANE KNIFE

Barcode	Product No.	Description	Pack Qty	Price
	180-85-00002	700ML VENUS FLY TRAP	12	

Barcode	Product No.	Description	Pack Qty	Price
	180-85-00003	FLY TRAP BAIT - 4 X 20GM PACKS ENVIRONMENTALLY FRIENDLY	12	

•SAFE AROUND CHILDREN & PETS •ENVIRONMENTALLY FRIENDLY •INCLUDES 100% ORGANIC BAIT



Barcode	Product No.	Description	Pack Qty	Price
	190-55-44251	400MM MACHETE	10	

Barcode	Product No.	Description	Pack Qty	Price
	190-47-44253	CANE KNIFE	8	

•WITH SHEATH •WOOD HANDLE

•WOOD HANDLE



Barcode	Product No.	Description	Pack Qty	Price
	190-47-44254	CANE KNIFE LONG HANDLE 650MM	12	

Barcode	Product No.	Description	Pack Qty	Price
	190-78-08060	SPLINE ROLLER	10	

•WOODEN HANDLE •OVERALL LENGTH 650MM

•PLASTIC



## GARDEN TOOLS

Barcode	Product No.	Description	Pack Qty	Price
	190-77-43801	GRASS SHEARS	6	

•SHEEP SHEAR PATTERN



Barcode	Product No.	Description	Pack Qty	Price
	190-77-43313	PRUNING SECATEUR	6	

• SWISS PATTERN •BYPASS ACTION • 200MM



Barcode	Product No.	Description	Pack Qty	Price
	190-77-43050	TELESCOPIC STRAIGHT BLADE HEDGE SHEARS	6	

•TELESCOPIC HANDLE •WAVY BLADE •750MM LENGTH OVERALL



Barcode	Product No.	Description	Pack Qty	Price
	190-77-43010	ANVIL PRO LOPPING SHEARS	6	

•STEEL BLADES •FORGED BLADES FOR ADDED STRENGTH  
•RUBBER HANDLE WITH COMFORTABLE CONTOURED GRIPS

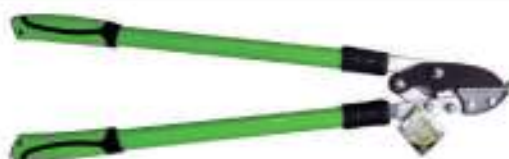

Barcode	Product No.	Description	Pack Qty	Price
	190-58-44420	750 GRAM MINI MATTOCK	6	

•PP COATED FIBREGLASS HANDLE



Barcode	Product No.	Description	Pack Qty	Price
	190-58-44417	1.2KG WOODEN HANDLE MINI MATTOCK	6	

•PICK END MATTOCK •WOODEN HANDLE



Barcode	Product No.	Description	Pack Qty	Price
	190-58-44419	5LB PICK END MATTOCK	6	

•900MM FIBREGLASS HANDLE



Barcode	Product No.	Description	Pack Qty	Price
	190-58-44412	2KG MATTOCK WITH CUTTER END	6	

•900MM PP COATED FIBREGLASS HANDLE





# GreenLeaf

GARDEN, RURAL & LEISURE

## AXES/BLOCKSPLITTERS

Barcode	Product No.	Description	Pack Qty	Price
	190-04-05611	1 3/4LB HATCHET FIBREGLASS HANDLE	6	
<b>•350MM PP COATED FIBREGLASS HANDLE</b>				



Barcode	Product No.	Description	Pack Qty	Price
	190-04-05613	2 LB AXE WITH F/GLASS HANDLE	6	
<b>•600MM PP COATED FIBREGLASS HANDLE</b>				



Barcode	Product No.	Description	Pack Qty	Price
	190-04-05614	4 LB AXE WITH F/GLASS HANDLE	6	
<b>•850MM PP COATED FIBREGLASS HANDLE</b>				



Barcode	Product No.	Description	Pack Qty	Price
	190-04-05626	2KG SPLITTING AXE	6	
<b>• 600MM PP COATED •FIBREGLASS HANDLE •CARBON STEEL DROP FORGED HEAD</b>				



Barcode	Product No.	Description	Pack Qty	Price
	190-36-05617	6 LB BLOCK SPLITTER	6	
<b>•850MM FIBREGLASS HANDLE</b>				



Barcode	Product No.	Description	Pack Qty	Price
	190-04-05627	2KG SPLITTING AXE WITH BEECH WOOD HANDLE	6	
<b>•CARBON STEEL DROP FORGED HEAD •900MM BEECH WOOD HANDLE</b>				



Barcode	Product No.	Description	Pack Qty	Price
	190-36-05618	8 LB BLOCK SPLITTER	4	
<b>•850MM FIBREGLASS HANDLE</b>				



Barcode	Product No.	Description	Pack Qty	Price
	190-36-05630	6LB BLOCKSPLITTER WITH BEECH WOOD HANDLE	6	
<b>•CARBON STEEL DROP FORGED HEAD •900MM BEECH WOOD HANDLE</b>				





# GreenLeaf

GARDEN, RURAL & LEISURE

## SHOVELS

Barcode	Product No.	Description	Pack Qty	Price
	190-77-44518	AUTO / CAMPING SHOVEL	6	

•D GRIP HANDLE •630MM



Barcode	Product No.	Description	Pack Qty	Price
	190-77-44519	FOLDING CAMP SHOVEL	6	

•350MM HANDLE



Barcode	Product No.	Description	Pack Qty	Price
	190-77-44566	DIGGING SPADE	6	

•FIBREGLASS D GRIP HANDLE •1.05M LENGTH



Barcode	Product No.	Description	Pack Qty	Price
	190-77-44565	SQUARE MOUTH SHOVEL	6	

•FIBREGLASS D GRIP HANDLE •1.05M LENGTH



Barcode	Product No.	Description	Pack Qty	Price
	190-77-44501	SQUARE MOUTH SHOVEL METAL	6	

•MADE FROM HARDENED HEAT TREATED STEEL  
•MINIMUM ORDER QTY: 6



Barcode	Product No.	Description	Pack Qty	Price
	190-77-44502	SQUARE MOUTH SHOVEL YELLOW	6	

•MADE FROM HARDENED HEAT TREATED STEEL  
•MINIMUM ORDER QTY: 6



Barcode	Product No.	Description	Pack Qty	Price
	190-77-44503	SQUARE MOUTH SHOVEL GREEN	6	

•MADE FROM HARDENED HEAT TREATED STEEL  
•MINIMUM ORDER QTY: 6



Barcode	Product No.	Description	Pack Qty	Price
	190-77-44504	SQUARE MOUTH SHOVEL PINK	6	

•MADE FROM HARDENED HEAT TREATED STEEL  
•MINIMUM ORDER QTY: 6





# GreenLeaf

GARDEN, RURAL & LEISURE

## SHOVELS/FORK/FENCING

Barcode	Product No.	Description	Pack Qty	Price
	190-77-44567	SQUARE MOUTH SHOVEL	6	
<b>•1200MM FIBREGLASS HANDLE</b>				

Barcode	Product No.	Description	Pack Qty	Price
	190-77-44568	POST HOLE SHOVEL	6	
<b>•1200MM FIBREGLASS HANDLE</b>				



Barcode	Product No.	Description	Pack Qty	Price
	190-70-44542	2 HANDED POST HOLE DIGGER	4	
<b>•STEEL TUBULAR HANDLE</b>				

Barcode	Product No.	Description	Pack Qty	Price
	190-77-44535	PLASTIC GRAIN SCOOP	6	
<b>•D GRIP HANDLE</b>				



Barcode	Product No.	Description	Pack Qty	Price
	190-30-44111	4 TOOTH GARDEN FORK	6	
<b>•D TYPE FIBREGLASS HANDLE</b>				

Barcode	Product No.	Description	Pack Qty	Price
	190-30-44110	LANDSCAPERS FORK	6	
<b>•10 TEETH FORKS LONG WITH FIBREGLASS TUBULAR HANDLE</b>				



Barcode	Product No.	Description	Pack Qty	Price
	190-27-45992	FENCE POST DRIVER 800MM 8KG	6	
<b>•800MM, 8 KG. REINFORCED HANDLES</b>				

Barcode	Product No.	Description	Pack Qty	Price
	190-71-46000	RATCHET FENCE STRAINER	20	
<b>•HEAVY DUTY</b>				





# GreenLeaf

GARDEN, RURAL & LEISURE

## RAKES

Barcode	Product No.	Description	Pack Qty.	Price
	180-71-07145	450MM RAKE PLASTIC FAN HEAD	10	

	180-71-07146	600MM RAKE PLASTIC FAN HEAD	10	
--	--------------	--------------------------------	----	--

•PLASTIC HEAD •WOOD HANDLE



Barcode	Product No.	Description	Pack Qty.	Price
	190-71-07144	780MM RAKE PLASTIC METAL HANDLE 30T	10	

•PLASTIC HEAD •METAL HANDLE



Barcode	Product No.	Description	Pack Qty.	Price
	190-71-42026	LANDSCAPERS RAKE ALUMINIUM	6	

• 36 TEETH 1500MM • FIBREGLASS HANDLE  
• 920MM HEAD WIDTH



Barcode	Product No.	Description	Pack Qty.	Price
	190-71-42025	18T RAKE WITH STEEL HANDLE	6	

•18 TEETH RAKE HEAD •STEEL HANDLE •1.55M OVERALL LENGTH



Barcode	Product No.	Description	Pack Qty.	Price
	190-71-42023	STABLE RAKE	6	

•FIBREGLASS HANDLE •METAL HEAD



Barcode	Product No.	Description	Pack Qty.	Price
	190-77-44536	GUTTER SCOOP	36	

•SIZE: 425 X 80 X 95MM •WEIGHT: 100G •LARGE HOLDING  
CAPACITY •DURABLE ONE PIECE MOULDED PLASTIC





# GreenLeaf

GARDEN, RURAL & LEISURE

## CARTS

Barcode	Product No.	Description	Pack Qty	Price
	190-93-08745	DUMPING CART	1	

•85 LITRE CAPACITY •85 LITRE •10 X 3.50 INCH WHEELS  
•ASSEMBLY REQUIRED



Barcode	Product No.	Description	Pack Qty	Price
	190-93-08742	85L YARD CART	1	

•85 LITRE CAPACITY •350MM PNEUMATIC WHEELS  
•ASSEMBLY REQUIRED



Barcode	Product No.	Description	Pack Qty	Price
	190-32-08741	1016 X 521MM GARDEN CART	1	

•WEIGHT CAPACITY 300KG •BED SIZE 1016X521MM  
•PNEUMATIC WHEELS •ASSEMBLY REQUIRED



Barcode	Product No.	Description	Pack Qty	Price
	190-93-08747	200KG DUMPING CART PUSH/TOW	1	

200KG LOAD CAPACITY. DIMENSIONS: 1570X930X720MM.  
WHEEL SIZE: 16X4.00-8 •ASSEMBLY REQUIRED



Barcode	Product No.	Description	Pack Qty	Price
	190-32-08760	300KG TRAILER	1	

•STEEL PANEL AND BED •FOLDABLE SIDE PANELS •POWDER COATED FINISH • 16 X 4.00-8 PNEUMATIC WHEELS WITH POWDER COATED STEEL RIM •1050 x 775 x 335MM •ASSEMBLY REQUIRED



Barcode	Product No.	Description	Pack Qty	Price
	190-32-08755	200L YARD CART	1	

• 200 LITRE CAPACITY • POLY TRAY • 150KG LOAD CAPACITY  
• 400MM PNEUMATIC WHEELS • ASSEMBLY REQUIRED







# GreenLeaf

GARDEN, RURAL & LEISURE

## HOSE FITTINGS/HOSES

Barcode	Product No.	Description	Pack Qty	Price
	190-32-44471	5 PIECE HOSE SET	6	
<b>3/4 INCH. CARDED. SUITS 12MM HOSE</b>				



Barcode	Product No.	Description	Pack Qty	Price
	190-32-44472-B	8PCE BASIC GARDEN SET	6	
<b>•SUITS 12MM HOSE • CARDED</b>				



Barcode	Product No.	Description	Pack Qty	Price
	190-32-44497-B	5 PCE SPRINKLER & FITTING SET	6	
<b>•SUITS 12MM HOSE • CARDED</b>				



Barcode	Product No.	Description	Pack Qty	Price
	190-32-44462	4PCE BRASS GARDEN HOSE SET	6	
<b>•4 PIECE •BRASS •CARDED •SUITS 12MM HOSE</b>				



Barcode	Product No.	Description	Pack Qty	Price
	190-32-44493	DOME SPRINKLER	10	
<b>•DOME SPRINKLER WITH ROUND HOLE</b>				



Barcode	Product No.	Description	Pack Qty	Price
	190-32-44491	IMPULSE TRIPOD SPRINKLER	12	
<b>METAL LEGS •FOLDING LEGS •THROWS WATER UP TO 15M •DISTANCE CONTROL •ADJUSTABLE SPRAY PATTERN</b>				



Barcode	Product No.	Description	Pack Qty	Price
	190-32-44449	10M X 1/2 INCH GARDEN HOSE WITH FITTINGS	10	
	190-32-44457	20M X 1/2 INCH GARDEN HOSE WITH FITTINGS	5	
<b>•MATERIAL: PVC •CONNECTORS &amp; TRIGGER NOZZLE INCLUDED</b>				



Barcode	Product No.	Description	Pack Qty	Price
	190-32-44456	30M X 1/2 INCH GARDEN HOSE WITH FITTINGS	4	
<b>•MATERIAL: PVC •CONNECTORS &amp; PATTERN NOZZLE INCLUDED</b>				





# GreenLeaf

GARDEN, RURAL & LEISURE

## RAIN GAUGES/WATERING CANS

Barcode	Product No.	Description	Pack Qty	Price
	190-33-44610	RAIN GAUGE	6	

Barcode	Product No.	Description	Pack Qty	Price
	190 33 44612	RAIN GAUGE	6	

• CLEAR PLASTIC • 0 - 150ML • SUPPLIED WITH PLASTIC MOUNTING BRACKET

• 250ML CAPACITY IN 1MM INCREMENTS



Barcode	Product No.	Description	Pack Qty	Price
	190-78-44625	7.5L ROUND WATERING CAN	8	

Barcode	Product No.	Description	Pack Qty	Price
	190-78-44638	5L WATERING CAN	18	

• POWDER COATED

• CAPACITY: 5 LITRES • ANTI SPILL CAP • SIZE: 705 X 685 X 460MM • WEIGHT: 530G



Barcode	Product No.	Description	Pack Qty	Price
	190-78-44639	9L WATERING CAN	10	

• CAPACITY: 9 LITRES • ANTI SPILL CAP • SIZE: 705 X 690 X 380MM • WEIGHT: 730G





## SPRAYERS

Barcode	Product No.	Description	Pack Qty	Price
	190-78-44609	900ML SPRAY BOTTLE	45	

•900ML



Barcode	Product No.	Description	Pack Qty	Price
	190-78-44604	1LTR PRESSURE SPRAYER	20	

	190-78-44602	2LTR PRESSURE SPRAYER	20	
-----------------------------------------------------------------------------------	--------------	-----------------------	----	--

•2 LITRE •ADJUSTABLE NOZZLE •PUMP ACTION



Barcode	Product No.	Description	Pack Qty	Price
	190-78-44605	5 LITRE PRESSURE SPRAYER	6	

•ROBUST CONSTRUCTION •ADJUSTABLE NOZZLE •RELIEF VALVE  
•EASY TO USE ON/OFF TAP •LONG FLEXIBLE HOSE •CARRY STRAP



Barcode	Product No.	Description	Pack Qty	Price
	190-78-44608	8LTR PRESSURE SPRAYER	6	

•ROBUST CONSTRUCTION •ADJUSTABLE NOZZLE •RELIEF VALVE  
•EASY TO USE ON/OFF TAP •LONG FLEXIBLE HOSE •CARRY STRAP



Barcode	Product No.	Description	Pack Qty	Price
	190-78-44614	12L TROLLEY PRESSURE SPRAYER	1	

•12L •BRASS LANCE •3M HOSE NOZZLE •ALUMINIUM PUMP  
LEVER •EXTRA WIDE MOUTH FOR EASY FILL



Barcode	Product No.	Description	Pack Qty	Price
	190-78-44615	15 LITRE KNAPSACK	4	

•15 LITRE •ROBUST CONSTRUCTION •PLASTIC TANK •IN LINE  
FILTER •WIDE STRAP •ADJUSTABLE LANCE TAKE DIFFERENT  
NOZZLES SUPPLIED





# GreenLeaf

GARDEN, RURAL & LEISURE

## SPRAYERS

Barcode	Product No.	Description	Pack Qty	Price
	190-78-44626	1L HEAVY DUTY PRESSURE SPRAYER	20	

•1 LITRE CAPACITY •CHEMICAL RESISTANT VITON SEALS  
•ADJUSTABLE NOZZLE FROM MIST TO JET



Barcode	Product No.	Description	Pack Qty	Price
	190-78-44627	5L HEAVY DUTY PRESSURE SPRAYER	6	

•5 LITRE CAPACITY •CHEMICAL RESISTANT VITON SEALS  
•ADJUSTABLE NOZZLE •RELIEF VALVE •EASY TO USE ON/OFF TAP  
•LONG FLEXIBLE HOSE •CARRY STRAP



Barcode	Product No.	Description	Pack Qty	Price
	190-78-44628	8L HEAVY DUTY PRESSURE SPRAYER	6	

•8 LITRE CAPACITY •CHEMICAL RESISTANT VITON SEALS  
•ADJUSTABLE NOZZLE •RELIEF VALVE •EASY TO USE ON/OFF TAP  
•LONG FLEXIBLE HOSE •CARRY STRAP



Barcode	Product No.	Description	Pack Qty	Price
	190-78-44629	VITON SEAL SERVICE KIT	1	

•SUITS 5L & 8L HEAVY DUTY SPRAYERS



Barcode	Product No.	Description	Pack Qty	Price
	180-78-42005	5 LITRE STAINLESS STEEL SPRAYER	4	

•ADJUSTABLE BRASS NOZZLE •PRESSURE GAUGE  
•RELEASE VALVE S/S LANCE •CARRY STRAP



Barcode	Product No.	Description	Pack Qty	Price
	180 78 42008	8 LITRE STAINLESS STEEL SPRAYER	4	

•ADJUSTABLE BRASS NOZZLE •PRESSURE GAUGE  
•RELEASE VALVE S/S LANCE •CARRY STRAP





# GreenLeaf

GARDEN, RURAL & LEISURE

## SPRAYERS

Barcode	Product No.	Description	Pack Qty	Price
	150-78-44634	1L BATTERY SPRAYER	20	

- 3.0 VOLT • 2 X 1.5V AA BATTERIES • WORKING PRESSURE: 1.6 BAR • WORKING TIME: 90 MINUTES

Barcode	Product No.	Description	Pack Qty	Price
	150-78-44637	5L LITHIUM SPRAYER	6	

- WORKING CAPACITY: 5L • VOLTAGE: 3.7V • WORKING PRESSURE: 1.5 BAR • WORKING TIME: 150 MINUTES • CHARGING TIME: 3 HOURS



Barcode	Product No.	Description	Pack Qty	Price
	150-78-44635	7.2V 5L LITHIUM SPRAYER	6	

- 7.2V LITHIUM BATTERY • WORKING TIME: 90 MINUTES • CHARGING TIME: 3 HOURS • WORKING PRESSURE: 1.2 TO 1.8 BAR

Barcode	Product No.	Description	Pack Qty	Price
	1500-78-44636	10.8V 16L LITHIUM SPRAYER	1	

- 10.8V LITHIUM BATTERY • 3.5 HOURS CONTINUOUS WORKING TIME • HIGH PERFORMANCE DIAPHRAGM PUMP • TELESCOPIC METAL LANCE • CHARGING TIME: 3 HOURS



**IN BUILT BATTERY & CHARGER**





# GreenLeaf

GARDEN, RURAL & LEISURE

## WINDMILLS

Barcode	Product No.	Description	Pack Qty	Price	Barcode	Product No.	Description	Pack Qty	Price
	190-93-44574	ORNAMENTAL WINDMILL 1420MM	1			190-93-44579	WINDMILL 1420MM WITH WEATHER STATION	1	
	190-93-44576	ORNAMENTAL WINDMILL 1800MM	1			190-93-44584	WINDMILL 1800MM WITH WEATHER STATION	1	
	190-93-44578	ORNAMENTAL WINDMILL 2400MM	1			190-93-44580	WINDMILL 2400MM WITH WEATHER STATION	1	
<b>ORNAMENTAL. ASSEMBLY REQUIRED.</b>					<b>ORNAMENTAL. INCLUDES WEATHER STATION. ASSEMBLY REQUIRED.</b>				





# GreenLeaf

GARDEN, RURAL & LEISURE

## WINDMILLS

Barcode	Product No.	Description	Pack Qty	Price
	190-93-44586	FLORAL WINDSPINNERS TRELLIS	3	

Barcode	Product No.	Description	Pack Qty	Price
	190-93-44591	WINDSPINNER BRONZE AND BLUE	1	

SIZE: 2134 X 610 X 622MM. MATERIAL: STEEL. COLOUR: BRONZE. AUX LEGS TO SPIKE INTO GROUND FOR STABILITY. ORNAMENTAL. ASSEMBLY REQUIRED.

SIZE: 600 X 256 X 2100MM. COLOUR: BRONZE & BLUE. FLORAL DESIGN. AUX LEGS TO SPIKE INTO GROUND FOR STABILITY. ASSEMBLY REQUIRED

**SOLD IN BOX OF 3 ONLY**

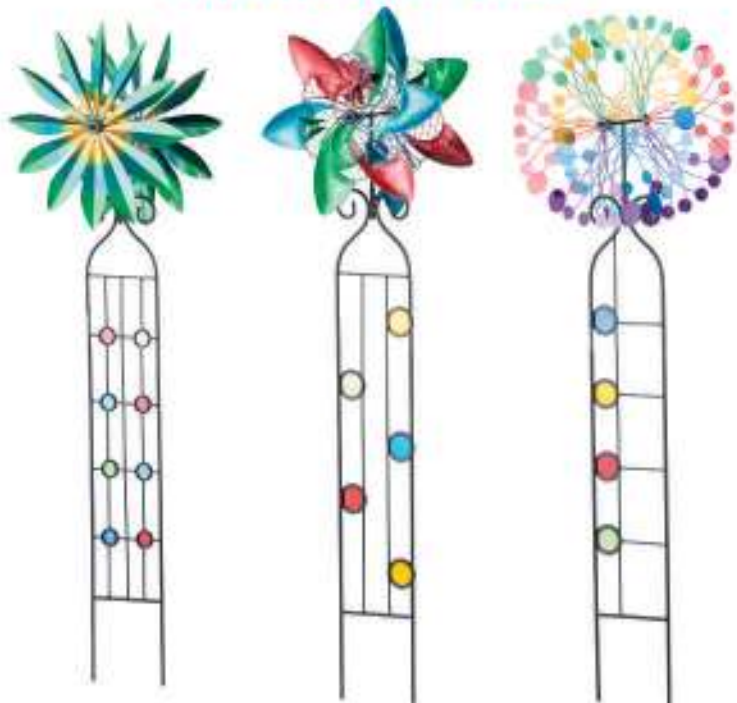

Barcode	Product No.	Description	Pack Qty	Price
	190-93-44592	WINDSPINNER BRONZE, GOLD & SILVER	1	

Barcode	Product No.	Description	Pack Qty	Price
	190-93-44583	ASSORTED FLORAL WIND SPINNERS	4	

SIZE: 600 X 2100MM. COLOUR: BRONZE, GOLD & SILVER. FLORAL DESIGN. AUX LEGS TO SPIKE INTO GROUND FOR STABILITY. ASSEMBLY REQUIRED

•SIZE: 1219 X 381 X 114MM •MATERIAL: STEEL  
•COLOUR: MULTI COLOURS •FOUR ASSORTED DESIGNS  
•ORNAMENTAL •ASSEMBLY REQUIRED.



**SOLD IN BOX OF 4 ONLY**





# GreenLeaf

GARDEN, RURAL & LEISURE

## ORNAMENTAL

Barcode	Product No.	Description	Pack Qty	Price	Barcode	Product No.	Description	Pack Qty	Price
	190-93-44581	DUAL SPINNER BRONZE WINDMILL	1			190-93-44582	TWISTED BLOOM BRONZE WINDMILL	1	

SIZE: 2134 X 610 X 622MM. MATERIAL: STEEL. COLOUR: BRONZE. AUX LEGS TO SPIKE INTO GROUND FOR STABILITY. ORNAMENTAL. ASSEMBLY REQUIRED.

SIZE: 2134 X 610 X 254MM. MATERIAL: STEEL. COLOUR: BRONZE. AUX LEGS TO SPIKE INTO GROUND FOR STABILITY. ORNAMENTAL. ASSEMBLY REQUIRED.





## GARDEN/OUTDOOR

Barcode	Product No.	Description	Pack Qty	Price
	190-67-14555	PET POOP N SCOOP	12	

• ONE HAND OPERATION. CAN BE USED ON GRASS, GRAVEL & HARD SURFACES. DURABLE & LIGHT WEIGHT.



Barcode	Product No.	Description	Pack Qty	Price
	160-76-08573	SOCK PROTECTORS	1 X 24PC	

**\$4.20 EACH** • WATER RESISTANT • STRETCH CUFF  
• 24 PAIR IN COUNTER DISPLAY BOX



Barcode	Product No.	Description	Pack Qty	Price
	190-32-44430	FERTILIZER SPREADER HANDHELD	8	

• SIZE: 240 X 225 X 210MM • IDEAL FOR SPREADING GRANULAR FERTILISER, HERBICIDES & PESTICIDES



Barcode	Product No.	Description	Pack Qty	Price
	190-11-68078	CANOPY	1	

• 3M X 6.1M • BALL BUNGEE TIE DOWNS • FOOT PLATES FOR SECURING FRAME TO GROUND



Barcode	Product No.	Description	Pack Qty	Price
	190-11-68079	COVER TO SUIT	1	

• SUITS 190-11-68078 CANOPY





# GreenLeaf

GARDEN, RURAL & LEISURE

## TARPAULINS

Barcode	Product No.	Description	Pack Qty	Price	Barcode	Product No.	Description	Pack Qty	Price
	190-81-59000	BLUE POLY TARP 1.2M x 1.8M	10			190-81-59025	SILVER POLY TARP 1.8M x 2.4M	10	
	190-81-59003	BLUE POLY TARP 1.8M x 2.4M	10			190-81-59028	SILVER POLY TARP 2.4M x 3.0M	10	
	190-81-59006	BLUE POLY TARP 2.4M x 3.0M	10			190-81-59030	SILVER POLY TARP 3.0M x 5.4M	6	
	190-81-59009	BLUE POLY TARP 3.0M x 3.6M	5			190-81-59031	SILVER POLY TARP 3.0M x 3.6M	6	
	190-81-59012	BLUE POLY TARP 3.6M x 4.8M	10			190-81-59032	SILVER POLY TARP 3.6M x 3.6M	8	
	190-81-59015	BLUE POLY TARP 3.6M x 6.0M	8			190-81-59033	SILVER POLY TARP 3.6M x 5.4M	6	
	190-81-59016	BLUE POLY TARP 3.6M x 7.6M	6			190-81-59034	SILVER POLY TARP 3.6M x 4.8M	6	
	190-81-59018	BLUE POLY TARP 5.4M x 6.0M	5			190-81-59035	SILVER POLY TARP 4.8M x 6.0M	4	
	190-81-59021	BLUE POLY TARP 6.0M x 9.0M	3			190-81-59036	SILVER POLY TARP 4.8M x 7.3M	3	

•BLUE •MEDIUM DUTY •U.V. STABILISED •ROPE REINFORCED EDGES



	190-81-59037	SILVER POLY TARP 3.6M x 6.5M	5	
	190-81-59038	SILVER POLY TARP 6.0M x 6.0M	3	
	190-81-59039	SILVER POLY TARP 6.0M x 7.2M	3	
	190-81-59042	SILVER POLY TARP 7.2M x 9.0M	1	
	190-81-59045	SILVER POLY TARP 9.0M x 9.0M	1	

•SILVER /BLACK •14 X 14 WEAVE •U.V. STABILISED •ROPE REINFORCED EDGES •REINFORCED CORNERS





**Queen**



**CLEANING  
PRODUCTS**

# Queen CLEANING PRODUCTS

## Introduction

Queen Cleaning is an Australian owned company that has been trading for over 50 years. Having expanded over the years to include a broad variety of cleaning products designed to meet consumer demand.

The Queen range is a mix of tradition with function, innovation and design. Queen currently offers top quality millet brooms, entry price level core cleaning lines, trade quality natural fibre industrial brooms and an ever growing storage category.

Increase your bottom line and give Queen consideration today.

Further information can be found on our website at [www.electaserv.com.au](http://www.electaserv.com.au)



## QUEEN MILLET BROOM

Barcode	Product No.	Description	Pack Qty	Price
	Q-2224	5 TIE CHAMPION MILLET BROOM	6	

•MILLET & CANE MIX •METAL HANDLE



Barcode	Product No.	Description	Pack Qty	Price
	Q-60749	5 TIE 500MM OUTDOOR BROOM	6	

• SYNTHETIC BRISTLES • METAL HANDLE • SUITABLE FOR WET OR DRY SURFACES



## QUEEN MILLET BROOM

Barcode	Product No.	Description	Pack Qty	Price
 9 516231 922744	Q-2274	7 TIE YARDMASTER MILLET BROOM	5	

•OUTDOOR BROOM •METAL HANDLE



Barcode	Product No.	Description	Pack Qty	Price
 9 516231 011717	Q-1171	8 TIE QUEEN OF BROOMS	6	

•100% MILLET •METAL HANDLE



**QUEEN MILLET BROOMS**

Barcode	Product No.	Description	Pack Qty	Price
	Q-1176	8 TIE ORIGINAL WOOLSHED BROOM	6	

•1250G MILLET FILL •28MM WOODEN HANDLE



Barcode	Product No.	Description	Pack Qty	Price
	Q-1174	10 TIE CLASSIC MILLET BROOM	6	

•EXTRA LONG DENSE FILL OF MILLET •METAL HANDLE



## QUEEN DUSTPANS/TOILET TIDY

Barcode	Product No.	Description	Pack Qty	Price	Barcode	Product No.	Description	Pack Qty	Price
	Q-LC0408	DUST PAN SET	12			Q-60649	LARGE DUST PAN SET	12	
<b>•CONVENIENT SIZE</b>					<b>•GREAT FOR OUTDOOR DUTIES •HEAVY DUTY</b>				



Barcode	Product No.	Description	Pack Qty	Price	Barcode	Product No.	Description	Pack Qty	Price
	Q-LC0415	LONG HANDLED DUST PAN SET	12			Q-3200W	COBWEB BROOM WITH TELESCOPIC HANDLE	12	
<b>•NO BACK BENDING •BRUSH CLIPS TO DUSTPAN</b>					<b>•TELESCOPIC HANDLE •EXTENDS 1560MM</b>				



Barcode	Product No.	Description	Pack Qty	Price	Barcode	Product No.	Description	Pack Qty	Price
	Q-4462	TOILET TIDY SET HANGING STAND	12			Q-70160	TOILET TIDY UPRIGHT AND OPEN	6	
<b>•PLASTIC STAND •HANGING BRUSH</b>					<b>•DOUBLE HEADED BRUSH •SPASH BACK FOR LESS MESS</b>				





## QUEEN BROOMS

Barcode	Product No.	Description	Pack Qty	Price
	Q-LC0402	STANDARD BROOM	12	

•SUITABLE FOR LIGHT JOBS •METAL HANDLE



Barcode	Product No.	Description	Pack Qty	Price
	Q-70800	PREMIUM INDOOR BROOM	4	

•DENSE FILL OF LIGHT BRISTLES •METAL HANDLE



Barcode	Product No.	Description	Pack Qty	Price
	Q-60648	GARDEN BROOM	12	

•METAL HANDLE •STIFF BRISTLES



Barcode	Product No.	Description	Pack Qty	Price
	Q-60654	300MM SCRUBBING BROOM	12	

•HARD PP BRISTLE •WITH SQUEEGEE •WOODEN HANDLE



Barcode	Product No.	Description	Pack Qty	Price
	Q-1162	22MM X 1.35 WOODEN HANDLE	25	

Barcode	Product No.	Description	Pack Qty	Price
	Q-1167	25MM X 1.50 WOODEN HANDLE	25	

•STRONG WOODEN HANDLE •SUITES TRADE SERIES BROOMS



**NOTE: PRODUCT REQUIRES ASSEMBLY**

## QUEEN OUTDOOR & TRADE BROOMS

Barcode	Product No.	Description	Pack Qty	Price
	Q-355BCH	355MM BASSINE CANE TIMBER BROOM	3	

•NATURAL FIBRE •1500 X 25MM WOODEN HANDLE

**NOTE: PRODUCT REQUIRES ASSEMBLY**



Barcode	Product No.	Description	Pack Qty	Price
	Q-355BH	350MM BASSINE TIMBER BROOM	3	

•HARD HEAVY DUTY BRISTLES / DIRT & GREASE  
•1500MM WOODEN HANDLE •NATURAL FIBRE

**NOTE: PRODUCT REQUIRES ASSEMBLY**



Barcode	Product No.	Description	Pack Qty	Price
	Q-455BH	450MM BASSINE TIMBER BROOM	6	
	Q-610BH	610MM BASSINE TIMBER BROOM	3	

•HARD HEAVY DUTY BRISTLES / DIRT & GREASE •1500MM  
WOODEN HANDLE & STAY •NATURAL FIBRE

**NOTE: PRODUCT REQUIRES ASSEMBLY**



Barcode	Product No.	Description	Pack Qty	Price
	Q-610CH	610MM COCO FIBRE TIMBER BROOM	3	
	Q-910CH	910MM COCO FIBRE TIMBER BROOM	3	

•FOR SMOOTH DRY AND DUSTY FLOORS •1500MM  
WOODEN HANDLE & STAY •NATURAL FIBRE

**NOTE: PRODUCT REQUIRES ASSEMBLY**



## QUEEN OUTDOOR & TRADE BROOMS

Barcode	Product No.	Description	Pack Qty.	Price
	Q-450M	450MM INDUSTRIAL MIX POLY BROOM	6	
	Q-600P	600MM INDUSTRIAL MIX POLY BROOM	6	

•HARD PP BRISTLES COVER SOFT PP FIBRE •METAL HANDLE & THREAD



Barcode	Product No.	Description	Pack Qty.	Price
	Q-450HH	450MM HARD BRISTLE POLY BROOM	6	
	Q-600HH	600MM HARD BRISTLE POLY BROOM	6	

•DENSE FILL OF HARD PP BRISTLES •METAL HANDLE & THREAD •SOFT GRIP HANDLE



Barcode	Product No.	Description	Pack Qty.	Price
	Q-45045	450MM IND MIX POLY BROOM	6	
	Q-60600	610MM IND MIX POLY BROOM	6	

•HARD PP BRISTLES COVER SOFT PP FIBRE  
•1500MM WOODEN HANDLE & STAY



**NOTE: PRODUCT REQUIRES ASSEMBLY**

## QUEEN MOPS/MOP BUCKETS

Barcode	Product No.	Description	Pack Qty	Price
	Q-LC0510	EZY-WRING SQUEEZE MOP	6	

•ABSORBENT COTTON



Barcode	Product No.	Description	Pack Qty	Price
	Q-LC2350	350GM COTTON MOP WITH 1.2M HANDLE	6	

350GM ABSORBENT COTTON. METAL HANDLE



Barcode	Product No.	Description	Pack Qty	Price
	Q-70630	MICROFIBRE MOP 350MM	6	

•36000 ULTRA THIN FIBRES PER SQ INCH  
•GREAT FOR PICKING UP DUST PARTICLES



Barcode	Product No.	Description	Pack Qty	Price
	Q-60606	16LT MOBILE PLASTIC MOP BUCKET	2	

•HEAVY DUTY •BRASS CASTORS



## QUEEN SQUEEGEE/BATHROOM & LAUNDRY

Barcode	Product No.	Description	Pack Qty	Price
	190-80-48036	WINDOW SQUEEGEE	24	
<b>•400MM WOODEN HANDLE</b>				



Barcode	Product No.	Description	Pack Qty	Price
	Q-60652	600MM RUBBER SQUEEGEE	12	
<b>• 1400MM METAL HANDLE. 600MM SQUEEGEE HEAD</b>				



Barcode	Product No.	Description	Pack Qty	Price
	Q-LC4450	45CM METAL FLOOR SQUEEGEE	6	
	Q-LC4460	60CM METAL FLOOR SQUEEGEE	6	
<b>•ALUMINUM BACKING •Q-1167 HANDLE TO SUIT •25X1500MM HANDLE</b>				



Barcode	Product No.	Description	Pack Qty	Price
	180-84-08474	LAUNDRY TROLLEY	4	
<b>•STRONG WHEELS •HEAVY DUTY SQUARE FRAME CONSTRUCTION •FOLDS AWAY</b>				



Barcode	Product No.	Description	Pack Qty	Price
	180-79-00140	2 STEP PLASTIC STOOL	6	
<b>•1ST STEP 19CM HIGH•2ND STEP 33CMS HIGH•WEIGHT LIMIT 100KGS</b>				



Barcode	Product No.	Description	Pack Qty	Price
	190-58-11094	RUBBER FLOOR MAT INDUSTRIAL QUALITY	1	
<b>• NON SLIP •OIL RESISTANT •SIZE: 1524 X 914MM •ANTI FATIGUE •MATERIAL: RUBBER</b>				



## QUEEN PAILS

Barcode	Product No.	Description	Pack Qty	Price	Barcode	Product No.	Description	Pack Qty	Price
	180-10-00101	1L PLASTIC BUCKET	8			180-10-00111	3L PLASTIC BUCKET	8	
•SEALABLE LID •PLASTIC HANDLE •MINIMUM ORDER QTY: 8					•SEALABLE LID •PLASTIC HANDLE •MINIMUM ORDER QTY: 8				

**FOOD  
GRADE  
MATERIAL**



**FOOD  
GRADE  
MATERIAL**



Barcode	Product No.	Description	Pack Qty	Price	Barcode	Product No.	Description	Pack Qty	Price
	180-10-00094	5L PLASTIC BUCKET	8			180-10-00096	10L PLASTIC BUCKET	8	
•SEALABLE LID •PLASTIC HANDLE •MINIMUM ORDER QTY: 8					•SEALABLE LID •METAL HANDLE •MINIMUM ORDER QTY: 8				

**FOOD  
GRADE  
MATERIAL**



**FOOD  
GRADE  
MATERIAL**



Barcode	Product No.	Description	Pack Qty	Price	Barcode	Product No.	Description	Pack Qty	Price
	180-10-00098	20L PLASTIC BUCKET	8			180-10-00079	30L PLASTIC BUCKET WITH SCREW LID	8	
•SEALABLE LID •METAL HANDLE •MINIMUM ORDER QTY: 8					• SCREW TOP LID •METAL HANDLE •MINIMUM ORDER QTY: 8				

**FOOD  
GRADE  
MATERIAL**



**FOOD  
GRADE  
MATERIAL**



## QUEEN MEASURING BUCKETS & DRUMS

Barcode	Product No.	Description	Pack Qty	Price	Barcode	Product No.	Description	Pack Qty	Price
	180-10-00116	5 LITRE TRANSPARENT PLASTIC BUCKET	40			180-10-00117	10 LITRE TRANSPARENT PLASTIC BUCKET	20	

•LARGE CAPACITY •MEASUREMENT INCREMENTS  
•WITH LID

•LARGE CAPACITY •MEASUREMENT INCREMENTS  
•WITH LID

**FOOD  
GRADE  
MATERIAL**



**FOOD  
GRADE  
MATERIAL**



Barcode	Product No.	Description	Pack Qty	Price	Barcode	Product No.	Description	Pack Qty	Price
	180-10-00118	19 LITRE TRANSPARENT PLASTIC BUCKET	12			190-52-20510	5 PCE MEASURING JUG SET	4	

•LARGE CAPACITY •MEASUREMENT INCREMENTS  
•WITH LID

•250ML, 500ML, 1L, 2L & 5L •5 PIECE •MEASUREMENT  
INCREMENTS

**FOOD  
GRADE  
MATERIAL**



**FOOD  
GRADE  
MATERIAL**



Barcode	Product No.	Description	Pack Qty	Price	Barcode	Product No.	Description	Pack Qty	Price
	180-10-00121	30 LITRE PLASTIC DRUMS	9			180-10-00122	50 LITRE PLASTIC DRUMS	6	

•SIZE: 32 x 18.5 x 39.5CM •WEIGHT: 800G •SIDE  
HANDLES •SCREW CAP

•SIZE: 33.5 x 19 x 44CM •WEIGHT: 1550G •SCREW CAP  
•SIDE HANDLES

**FOOD  
GRADE  
MATERIAL**



**FOOD  
GRADE  
MATERIAL**



## QUEEN BUCKETS

Barcode	Product No.	Description	Pack Qty	Price
	Q-60670	10L CONCRETTERS RUBBER BUCKET	10	

•METAL HANDLE



Barcode	Product No.	Description	Pack Qty	Price
	Q-60686	14L CONCRETTERS RUBBER BUCKET	10	

METAL HANDLE. HEAVY DUTY BUCKET.



Barcode	Product No.	Description	Pack Qty	Price
	Q-60690	20L CONCRETTERS RUBBER BUCKET	10	

METAL HANDLE. HEAVY DUTY BUCKET.



Barcode	Product No.	Description	Pack Qty	Price
	Q-92012	10L BUCKET WITH POURING SPOUT	36	

•METAL HANDLE •GREAT SIZE •MINIMUM ORDER QTY: 36 UNITS



Barcode	Product No.	Description	Pack Qty	Price
	Q-92022	12L PLASTIC BUCKET	12	

•HEAVY DUTY VIRGIN PLASTIC •METAL HANDLE  
• ASSORTED COLOURS: BLUE, RED & YELLOW •MINIMUM ORDER QTY: 12 UNITS



Barcode	Product No.	Description	Pack Qty	Price
	Q-92014	9L PLASTIC OBLONG BUCKETS	36	

•IDEAL MOP BUCKET • WITH SPOUT



Barcode	Product No.	Description	Pack Qty	Price
	Q-60607	9L PLASTIC RECTANGULAR BUCKET	12	

• RECTANGULAR DESIGN WITH POURING SPOUT  
• PLASTIC HANDLE • ASSORTED COLOURS: GREEN, RED & YELLOW





## QUEEN METAL BUCKETS

Barcode	Product No.	Description	Pack Qty	Price
	Q-40016	8LTR STAINLESS STEEL BUCKET	6	
<b>•FULLY SPUN BASE •STAINLESS STEEL •HEAVY DUTY</b>				



Barcode	Product No.	Description	Pack Qty	Price
	Q-40017	12LTR STAINLESS STEEL BUCKET	6	
<b>•FULLY SPUN BASE •STAINLESS STEEL •HEAVY DUTY</b>				



Barcode	Product No.	Description	Pack Qty	Price
	Q-40018	16LTR STAINLESS STEEL BUCKET	6	
<b>•FULLY SPUN BASE •STAINLESS STEEL •HEAVY DUTY</b>				



Barcode	Product No.	Description	Pack Qty	Price
	Q-40022	15L STAINLESS STEEL BUCKET	12	
<b>CLEAN &amp; SHINY FINISH. 0.28MM THICKNESS. METAL HANDLE</b>				



Barcode	Product No.	Description	Pack Qty	Price
	Q-40020	10LT STAINLESS STEEL BUCKET	12	
<b>CLEAN &amp; SHINY FINISH. 0.28MM THICKNESS. METAL HANDLE</b>				



Barcode	Product No.	Description	Pack Qty	Price
	Q-40010	10LT BUCKET GALVANISED	10	
	Q-40015	15LT BUCKET GALVANISED	10	
<b>•GALVANISED •METAL HANDLE</b>				



## QUEEN STORAGE

Barcode	Product No.	Description	Pack Qty	Price
	Q-60681	16L FLEXI TUB	12	

•FLEXIBLE TUBS•SO MANY USES•ASSORTED COLOURS



Barcode	Product No.	Description	Pack Qty	Price
	Q-60682	26L FLEXI TUB	6	

•FLEXIBLE TUBS•SO MANY USES•ASSORTED COLOURS



Barcode	Product No.	Description	Pack Qty	Price
	Q-60683	42L FLEXI TUB	6	

•FLEXIBLE TUBS•SO MANY USES•ASSORTED COLOURS



Barcode	Product No.	Description	Pack Qty	Price
	Q-60684	60L FLEXI TUB	6	

•FLEXIBLE TUBS•SO MANY USES•ASSORTED COLOURS



Barcode	Product No.	Description	Pack Qty	Price
	Q-60738	15L SQUARE FLEXI TUB	12	

• COLOUR: PURPLE • SIZE: 365 X 300 X 285MM  
• FLEXIBLE • IDEAL FOR KID'S TOYS, LAUNDRY & STORAGE  
•MEASUREMENT INCREMENTS



Barcode	Product No.	Description	Pack Qty	Price
	Q-60739	25L SQUARE FLEXI TUB	12	

• COLOUR: YELLOW • SIZE: 400 X 320 X 350MM  
• FLEXIBLE • IDEAL FOR KID'S TOYS, LAUNDRY & STORAGE  
•MEASUREMENT INCREMENTS



Barcode	Product No.	Description	Pack Qty	Price
	Q-60740	40L SQUARE FLEXI TUB	12	

• COLOUR: RED • SIZE: 470 X 400 X 385MM • FLEXIBLE  
• IDEAL FOR KID'S TOYS, LAUNDRY & STORAGE  
•MEASUREMENT INCREMENTS



## QUEEN STORAGE

Barcode	Product No.	Description	Pack Qty	Price	Barcode	Product No.	Description	Pack Qty	Price
	Q-60667	50L PLASTIC STORAGE BOX 510 X 360 X 276MM	6			Q-60666	40L PLASTIC STORAGE BOX 790 X 385 X 160MM	6	
<b>•CLEAR COLOUR •WHEELS FITTED •LOCK DOWN LID</b>					<b>•CLEAR COLOUR •LOCK DOWN LID</b>				



Barcode	Product No.	Description	Pack Qty	Price	Barcode	Product No.	Description	Pack Qty	Price
	Q-60665	35L PLASTIC STORAGE BOX 465 X 335 X 250MM	6			Q-60668	70L PLASTIC STORAGE BOX 630 X 435 X 360MM	6	
<b>•CLEAR COLOUR •WHEELS FITTED •LOCK DOWN LID</b>					<b>•CLEAR COLOUR •WHEELS FITTED •LOCK DOWN LID</b>				



## QUEEN STORAGE

Barcode	Product No.	Description	Pack Qty	Price	Barcode	Product No.	Description	Pack Qty	Price
	Q-60726	15L HEAVY DUTY STORAGE BOX	24			Q-60727	32L HEAVY DUTY STORAGE BOX	15	
<p>• 15 LITRE CAPACITY • SIZE: 450 X 300 X 190MM • MATERIAL: VIRGIN PP • LOCK DOWN LIDS • ASSORTED COLOURS: BLUE, RED &amp; YELLOW</p>					<p>• 32 LITRE CAPACITY • SIZE: 630 X 420 X 195MM • MATERIAL: VIRGIN PP • LOCK DOWN LIDS • ASSORTED COLOURS: BLUE, RED &amp; YELLOW</p>				



Barcode	Product No.	Description	Pack Qty	Price	Barcode	Product No.	Description	Pack Qty	Price
	Q-60728	55L HEAVY DUTY STORAGE BOX	12			Q-60620	58L STORAGE TUB (WITHOUT LID)	1	
<p>• 55 LITRE CAPACITY • SIZE: 630 X 420 X 310MM • MATERIAL: VIRGIN PP • LOCK DOWN LIDS • ASSORTED COLOURS: BLUE, RED &amp; YELLOW</p>					<p>• SIZE: 44 X 67 X 26.5CM • WEIGHT: 1.5KG • MATERIAL: PLASTIC RECYCLED PP • STACKABLE</p>				



## QUEEN BINS

Barcode	Product No.	Description	Pack Qty	Price	Barcode	Product No.	Description	Pack Qty	Price
	Q-60734	15L SLIMLINE SWING TOP BIN	20			Q-60735	20L SLIMLINE SWING TOP BIN	16	
<p>• 15 LITRE CAPACITY • SIZE: 305 X 210 X 450MM • MATERIAL: VIRGIN PP • SWING TOP LID • COLOUR: WHITE • SLIMLINE DESIGN</p>					<p>• 20 LITRE CAPACITY • SIZE: 355 X 255 X 475MM • MATERIAL: VIRGIN PP • SWING TOP LID • COLOUR: WHITE • SLIMLINE DESIGN</p>				



Barcode	Product No.	Description	Pack Qty	Price	Barcode	Product No.	Description	Pack Qty	Price
	Q-60736	30L SLIMLINE SWING TOP BIN	16			Q-60655	20L SWING TOP BIN •35 X 22 X 36CMS	5	
<p>• 30 LITRE CAPACITY • SIZE: 430 X 310 X 560MM • MATERIAL: VIRGIN PP • SWING TOP LID • COLOUR: WHITE • SLIMLINE DESIGN</p>					<p>• 20 LITRE CAPACITY • SIZE: 35 X 22 X 36CMS • MATERIAL: VIRGIN PP • COLOUR: WHITE</p>				



Barcode	Product No.	Description	Pack Qty	Price	Barcode	Product No.	Description	Pack Qty	Price
	Q-60656	30L SWING TOP BIN •41 X 26 X 48CMS	5			Q-60657	50L SWING TOP BIN 47 X 31 X 60CMS	5	
<p>• 30 LITRE CAPACITY • SIZE: 41 X 26 X 48CMS • MATERIAL: VIRGIN PP • COLOUR: WHITE</p>					<p>• 50 LITRE CAPACITY • SIZE: 47 X 31 X 60CMS • MATERIAL: VIRGIN PP • COLOUR: WHITE</p>				



## QUEEN BINS

Barcode	Product No.	Description	Pack Qty	Price	Barcode	Product No.	Description	Pack Qty	Price
	Q-40055	55LT GALVANISED STORAGE BIN	5			Q-60713	20L PEDAL BIN	4	
	Q-40075	75LT GALVANISED STORAGE BIN	5						

•GALVANISED •LOCK DOWN LID •METAL HANDLES

•SIZE: 30.5 X 30 X 45.5CM • PEDAL OPERATION • PP PLASTIC BIN WITH A SILVER FILM COATING



Barcode	Product No.	Description	Pack Qty	Price	Barcode	Product No.	Description	Pack Qty	Price
	Q-60623	60L PLASTIC RUBBISH BIN	10			Q-60712	40L PEDAL BIN	6	
	Q-60624	70L PLASTIC RUBBISH BIN	10						

• SIDE HANDLES •LOCK DOWN LID •HEAVY DUTY PLASTIC

•SIZE: 34 X 30 X 70CM • PEDAL OPERATION • PP PLASTIC BIN WITH A SILVER FILM COATING



## QUEEN WHEELIE BINS

Barcode	Product No.	Description	Pack Qty	Price
	160-10-50147	PLASTIC WHEELIE BIN 45L BLUE	2	

CASTORS FOR EASY MOVEMENT. DIMENSIONS:  
535(H) X 410(W) X 450MM(D). WEIGHT: 2KG



**NEW PACKAGING  
SOLD IN PACKS OF 2  
ONLY**

Barcode	Product No.	Description	Pack Qty	Price
	160-10-50149	PLASTIC WHEELIE BIN 45L PINK	2	

CASTORS FOR EASY MOVEMENT. DIMENSIONS:  
535(H) X 410(W) X 450MM(D) WEIGHT: 2KG



**NEW PACKAGING  
SOLD IN PACKS OF 2  
ONLY**

Barcode	Product No.	Description	Pack Qty	Price
	160-10-50150	PLASTIC WHEELIE BIN 60L ORANGE	2	

CASTORS FOR EASY MOVEMENT. DIMENSIONS:  
645(H) X 425(W) X 470MM(D). WEIGHT: 2KG



**NEW PACKAGING  
SOLD IN PACKS OF 2  
ONLY**

Barcode	Product No.	Description	Pack Qty	Price
	160-10-50151	PLASTIC WHEELIE BIN 60L BLUE	2	

CASTORS FOR EASY MOVEMENT. DIMENSIONS:  
645(H) X 425(W) X 470MM(D). WEIGHT: 2KG



**NEW PACKAGING  
SOLD IN PACKS OF 2  
ONLY**

Barcode	Product No.	Description	Pack Qty	Price
	160-10-50166	MINI GENERAL WASTE WHEELIE BIN	2	

60 LITRE CAPACITY. SIZE: 645 (H) X 425(W) X 470MM(D)  
.MATERIAL: VIRGIN PP .CASTOR WHEELS FOR EASY  
MOVEMENT .COLOUR: GREEN BASE & RED LID



**NEW PACKAGING  
SOLD IN PACKS OF 2  
ONLY**

Barcode	Product No.	Description	Pack Qty	Price
	160-10-50168	MINI RECYCLING WHEELIE BIN	2	

60 LITRE CAPACITY. SIZE: 645 (H) X 425(W) X 470MM(D)  
.MATERIAL: VIRGIN PP .CASTOR WHEELS FOR EASY  
MOVEMENT .COLOUR: GREEN BASE & RED LID



**NEW PACKAGING  
SOLD IN PACKS OF 2  
ONLY**

## QUEEN WHEELIE BINS

Barcode	Product No.	Description	Pack Qty	Price
	160-10-50152	PLASTIC WHEELIE BIN 100L BLUE	2	

•LARGE CAPACITY QUALITY WHEELS •DIMENSIONS:  
800(H) X 465(W) X 540MM(D) •WEIGHT: 6KG

Barcode	Product No.	Description	Pack Qty	Price
	160-10-50154	WHEELIE BIN 240L GREEN	2	

•LARGE CAPACITY QUALITY WHEELS •DIMENSIONS:  
1065(H) X 575(W) X 725MM(D) •WEIGHT: 12.5KG



**NEW PACKAGING  
SOLD IN PACKS OF 2  
ONLY**

Barcode	Product No.	Description	Pack Qty	Price
	160-10-50153	WHEELIE BIN 120L RED	2	

•LARGE CAPACITY QUALITY WHEELS •DIMENSIONS:  
940(H) X 475(W) X 560MM(D) •WEIGHT: 7KG



**NEW PACKAGING  
SOLD IN PACKS OF 2  
ONLY**



**NEW PACKAGING  
SOLD IN PACKS OF 2 ONLY**



***Team***

*expect the best*

# Team

*expect the best*

The Team brand was founded by Henry Taft in the 1950's. Henry became well known in Australia for inventing one of the country's first life jackets, the TAFT. Innovation, Integrity and honesty has shaped the team culture and business ethos for nearly 60 years. Our constant goal is to provide, durable, affordable, comfortable and relevant products for our customers.



**Work Boots**

**Gum Boots**

**Industrial  
Wet Weather  
clothing**

**Waterproof  
Socks & Gloves**



**Everyday Wet  
Weather  
Solutions**

**Men's &  
Women's  
Rainwear**

**Fishing  
Rainwear**

**Kids  
Rainwear**

The team range offers a comprehensive solution for Industrial, Wet Weather Clothing & Footwear. This range is available now from Electaserv and will be supplied under our current trading items.

*Simply 'expect the best'.*

**Team**

*expect the best*

## EMERGENCY PONCHO

### PONCHO

- \*Made from clear vinyl
- \*Disposable clear poncho
- \*Comes in pocket size packet for emergency use
- \*One size fits all

### COUNTER DISPLAY BOX

- \*Clever design display box holds 30 Emergency Ponchos

**Code:** EP  
**Size:** One size  
**Colour:** Clear



**Team**

*expect the best*

## ALL CLEAR

### PONCHO

- Made from strong clear vinyl
- Reusable 3/4 length
- Attached hood
- One size

**CODE:** 255F  
**SIZE:** One Size  
**COLOUR:** Clear



### JACKET

- 2 front pockets
- Double buttoning system
- Adjustable hood
- Full back vent

**CODE:** 251J  
**SIZE:** S-3XL  
**COLOUR:** Clear

### COAT

- Mid-Calf length
- 2 front pockets
- Adjustable cuffs
- Attached hood
- Full back vent

**CODE:** FL66  
**SIZE:** S-3XL  
**COLOUR:** Clear



Sizes	S	M	L
251J - CLEAR	251J-S	251J-M	251J-L
251T - CLEAR	251T-S	251T-M	251T-L

Sizes	XL	2XL	3XL
251J - CLEAR	251J-XL	251J-2XL	251J-3XL
251T - CLEAR	251T-XL	251T-2XL	251T-3XL

Sizes	S	M	L
FL66 - CLEAR	FL66-S	FL66-M	FL66-L

Sizes	XL	2XL	3XL
FL66 - CLEAR	FL66-XL	FL66-2XL	FL66-3XL



### TROUSER

- Elastic waist
- Adjustable cuffs

**CODE:** 251T  
**SIZE:** S-3XL  
**COLOUR:** Clear



*expect the best*

## Jacket Trousers

### TRIPLE 5

- All purpose weather protection
- Made from PVC coated
- Polyester (both sides)
- Attached hood
- Reinforced front pockets
- Underarm venting
- Trousers co-ordinate with jacket



 Safety Yellow  
555J Jacket

 Safety Yellow  
555T (Trousers)

Sizes	Small	Medium	Large	Xtra Large
555J - JACKET	555J-S	555J-M	555J-L	555J-XL
555T - TROUSER	555T-S	555T-M	555T-L	555T-XL

Sizes	2Xtra Large	3Xtra Large	4Xtra Large
555J-JACKET	555J-2XL	555J-3XL	555J-4XL
555T - TROUSER	555T-2XL	555T-3XL	



*expect the best*

# TUFLITE SET

**DESCRIPTION:** Wet weather jacket & trouser set

**PRODUCT CODE:** TSL(lime) or TLSO(orange) or TLSN(navy)

## TUFLITE SET



### MATERIALS

**JACKET** | - Lightweight & durable PVC Polyester

**TROUSER** | - Lightweight & durable PVC Polyester

### SPECIFICATIONS

#### JACKET FEATURES

- Lightweight & durable
- Underarm and back venting
- Heavy duty zip
- Storm flap
- Attached, concealed hood
- Waterproof front pockets

#### JACKET SIZING

- S, M, L, XL, 2XL, 3XL or 4XL

#### JACKET COLOURS

- Lime, Orange or Navy

#### JACKET LIFE SPAN

- The use and application determines the life span of the jacket. Normal environments should provide 12 months of use, if appropriate care is taken

#### TROUSER FEATURES

- Lightweight & durable
- Open vent pockets
- Elastic cord waist
- Adjustable cuffs

#### TROUSER SIZING

- S, M, L, XL, 2XL, 3XL or 4XL

#### TROUSER COLOURS

- Lime, Orange or Navy

#### TROUSER LIFE SPAN

- The use and application determines the life span of the trouser. Normal environments should provide 12 months of use, if appropriate care is taken

### USES

#### GENERAL CONSTRUCTION MINING ENGINEERING AGRICULTURE FISHING INDUSTRY

- Highly suitable
- Widely used
- Widely used
- Highly suitable
- Highly suitable
- Widely used

#### FABRICATION WASTE DISPOSAL FORESTRY TRANSPORT MOTOR INDUSTRY METAL INDUSTRY

- Highly suitable
- Widely used
- Widely used
- Widely used
- Highly suitable
- Widely used

**Team**
*expect the best*

## TUFLITE SET

- Includes a Jacket and Trouser sold as a set
- All made from lightweight PVC Polyester
- Jacket: underarm and back venting, heavy duty zip, storm flap, attached concealed hood, waterproof front pockets, draw cord hem
- Trouser: elastic cord waist, adjustable cuffs, open vent pockets

**Fluro Lime**  
**TLSL**

**Navy**  
**TLSN**

**Fluro Orange**  
**TLSO**

Sizes	Small	Medium	Large	Xtra Large
TLSL - LIME	TLSL-S	TLSL-M	TLSL-L	TLSL-XL
TLSN - NAVY	TLSN-S	TLSN-M	TLSN-L	TLSN-XL
TLSO - ORANGE	TLSO-S	TLSO-M	TLSO-L	TLSO-XL

Sizes	2Xtra Large	3Xtra Large
TLSL - LIME	TLSL-2XL	TLSL-3XL
TLSN - NAVY	TLSN-2XL	TLSN-3XL
TLSO - ORANGE	TLSO-2XL	TLSO-3XL



*expect the best*

**DESCRIPTION:** Wet wewather reflective jacket & trouser set

**PRODUCT CODE:** RTL5L(lime) or RTL5O(orange)

## REFLECTIVE TUFLITE SET



### MATERIALS

**JACKET** | - Lightweight & durable PVC Polyester

**TROUSER** | - Lightweight & durable PVC Polyester

### SPECIFICATIONS

#### JACKET FEATURES

- Lightweight & durable
- Underarm and back venting
- Heavy duty zip, storm flap
- Attached, concealed hood
- Waterproof front pockets

#### JACKET SIZING

- S, M, L, XL, 2XL, or 3XL

#### JACKET COLOURS

- Lime or Orange

#### JACKET LIFE SPAN

- The use and application determines the life span of the jacket. Normal environments should provide 12 months of use, if appropriate care is taken

#### TROUSER FEATURES

- Lightweight & durable
- Open vent pockets
- Elastic cord waist
- Adjustable cuffs

#### TROUSER SIZING

- S, M, L, XL, 2XL, or 3XL

#### TROUSER COLOURS

- Lime or Orange

#### TROUSER LIFE SPAN

- The use and application determines the life span of the trouser. Normal environments should provide 12 months of use, if appropriate care is taken

### USES

**GENERAL CONSTRUCTION**  
**MINING**  
**ENGINEERING**  
**AGRICULTURE**  
**FISHING INDUSTRY**

- Highly suitable
- Widely used
- Widely used
- Highly suitable
- Highly suitable
- Widely used

**FABRICATION**  
**WASTE DISPOSAL**  
**FORESTRY**  
**TRANSPORT**  
**MOTOR INDUSTRY**  
**METAL INDUSTRY**

- Highly suitable
- Widely used
- Widely used
- Widely used
- Highly suitable
- Widely used



**Team**

*expect the best*



## TUFLITE SET - REFLECTIVE

- Includes a Jacket and Trouser sold as a set
- All made from lightweight PVC Polyester
- Jacket: underarm and back venting, heavy duty zip, storm flap, attached concealed hood, waterproof front pockets, draw cord hem & reflective taping
- Trouser: elastic cord waist, adjustable cuffs, open vent pockets, reflective taping

 **Fluro Lime**  
TL

 **Fluro Orange**  
TO

Sizes	Small	Medium	Large	Xtra Large
RTL	RTL-S	RTL-M	RTL-L	RTL-XL
RTLO	RTLO-S	RTLO-M	RTLO-L	RTLO-XL

Sizes	2Xtra Large	3Xtra Large
RTL	RTL-2XL	RTL-3XL
RTLO	RTLO-2XL	RTLO-3XL

**Team**

*expect the best*

**DESCRIPTION:** Wet weather protection & visibility

**PRODUCT CODE:** MONJ(jacket) or MONT(trouser)- sold separately

## MONSOON JACKET & TROUSER



### MATERIALS

**JACKET** | - Soft, durable conforming and breathable Tricot Polyurethane

**TROUSER** | - Soft, durable conforming and breathable Tricot Polyurethane

### SPECIFICATIONS

**JACKET STANDARDS** | - 3M reflective tape meets AS/NZS 4602:1999 & EN471

**JACKET FEATURES** | - Super lightweight and comfortable  
- Fluoro for visibility  
- Waterproof to 5000mm  
- Welded seams  
- Concealed hood  
- Adjustable arm cuffs  
- Waterproof storm flap

**JACKET SIZING** | - S, M, L, XL, 2XL or 3XL

**JACKET COLOURS** | - Lime or Orange

**JACKET LIFE SPAN** | - The use and application determines the life span of the jacket. Normal environments should provide 12 months of use, if appropriate care is taken

**TROUSER STANDARDS** | - 3M reflective tape meets AS/NZS 4602:1999 & EN471

**TROUSER FEATURES** | - Super lightweight and comfortable  
- Fluoro for visibility  
- Waterproof to 5000mm  
- Welded seams  
- Elasticated waist  
- Adjustable pull cords, toggles and stud cuffs

**TROUSER SIZING** | - S, M, L, XL, 2XL or 3XL

**TROUSER COLOURS** | - Lime or Orange

**TROUSER LIFE SPAN** | - The use and application determines the life span of the trouser. Normal environments should provide 12 months of use, if appropriate care is taken

### USES

**GENERAL CONSTRUCTION** | - Highly suitable  
- Widely used  
**MINING** | - Widely used  
**ENGINEERING** | - Highly suitable  
**AGRICULTURE** | - Highly suitable  
**FISHING INDUSTRY** | - Widely used

**FABRICATION** | - Highly suitable  
**WASTE DISPOSAL** | - Widely used  
**FORESTRY** | - Widely used  
**TRANSPORT** | - Widely used  
**MOTOR INDUSTRY** | - Highly suitable  
**METAL INDUSTRY** | - Widely used

**Team**

*expect the best*

● **Fluro Lime**  
**MONJ(Jacket)**  
**MONT(Trouser)**

## MONSOON

- Made from soft, yet durable conforming breathable Tricot PU
- Hi Vis with 3M reflective tape - complies with EN471, CLM85 and AS/NZ 4602:1999
- Super light weight, comfortable and waterproof to 5000mm
- Welded seams

### Jacket

- Concealed hood
- Adjustable arm cuffs
- Waterproof storm flap, zip and studs

### Trouser

- Elasticated waist with adjustable pull cords, toggle & stud cuffs



Sizes	Small	Medium	Large
MONJ - JACKET	MONJ-S	MONJ-M	MONJ-L
MONT -TROUSER	MONT-S	MONT-M	MONT-L

Sizes	Xtra Large	2Xtra Large	3Xtra Large
MONJ - JACKET	MONJ-XL	MONJ-2XL	MONJ-3XL
MONT -TROUSER	MONT-XL	MONT-2XL	MONT-3XL

**Team**

*expect the best*

**DESCRIPTION:** Complete waterproof comfort

**PRODUCT CODE:** WPG(gloves) WPS(socks)

## WATERPROOF GLOVES & SOCKS



### MATERIALS

#### OUTER LAYER

- Nylon and Elastine conform to your hands and feet to provide you with the most comfortable fit

#### MIDDLE LAYER

- The Waterproof & Breathable Membrane layer allows your hand and feet head to stay fully dry when submerged in water

#### INNER LAYER

- Cotton & Elastine provide warmth and comfort for your hands and feet

### SPECIFICATIONS

#### SPECIAL FEATURES

- Completely waterproof gloves and socks
- Remain completely dry when submerged in water

#### SIZING/COLOURS

- Gloves
- S/M or L/XL in Black/Blue
- Socks
- M (6-8), L (9-11) or XL (12-14) in Black/Blue

#### LIFE SPAN

- The use and application determines the life span of the gloves and socks. Normal environments should provide 12 months of use, if appropriate care is taken

### USES

#### GENERAL

- Highly suitable

#### CONSTRUCTION

- Widely used

#### MINING

- Widely used

#### ENGINEERING

- Highly suitable

#### AGRICULTURE

- Highly suitable

#### FOOD & HEALTH

- Widely used (reference to chemical resistance in cleaning areas may be necessary)

#### FISHING INDUSTRY

- Widely used

#### FABRICATION

- Highly suitable

#### FORESTRY

- Widely used

#### TRANSPORT

- Widely used

#### MOTOR INDUSTRY

- Highly suitable

#### METAL INDUSTRY

- Widely used (temperature limitations must be observed)



*expect the best*

## WATERPROOF GLOVES

- Fully waterproof and highly breathable
- Provide conforming comfort by moulding to your hand
- Durable wicking fabric is used to absorb moisture

**Black/Blue**  
WPG

Sizes	S/M	L/XL
WPG - BLACK/BLUE	WPG-S/M	WPG-L/XL



## WATERPROOF SOCKS

- Fully waterproof and highly breathable
- Provide conforming comfort by moulding to your feet
- Durable wicking fabric is used to absorb moisture

**Black/Blue**  
WPS

Sizes	M	L	XL
WPS - BLACK/BLUE	WPS-M	WPS-L	WPS-XL



*expect the best*

**DESCRIPTION:** The ultimate combination of safety and comfort

**PRODUCT CODE:** TSJB (black)

## SAFETY JOGGER



### MATERIALS

**UPPER**

- Leather and mesh upper

**LINING**

- Fully breathable mesh lining

**INNER-SOLE**

- Thick Neoprene inner-sole for extra comfort

**TOE CAP**

- Composite toe cap

**OUTER-SOLE**

- EVA conforming sole with PU, tough and durable

### SPECIFICATIONS

**STANDARDS**

- Meets AS/NZS 2210.3:2009 & EN345

**SPECIAL FEATURES**

- Padded collar and tongue for extra comfort  
- Stylish, comfortable design

**SOLE**

- Maximum temperature 90°C (degrees celcius)  
- Oil and acid resistant EVA sole

**TOE CAP**

- Composite toe cap - tested to an impact of 200 Joules

**SIZING/COLOURS**

- Available in Sizes 7 - 13 in Black & Sizes 7 - 12 in Blue (both unisex sizing)

**LIFE SPAN**

- The use and application determines the life span of the shoe. Normal environments should provide 12 months of use, if appropriate care is taken

### USES

**GENERAL**

- Highly suitable

**CONSTRUCTION**

- Widely used

**ENGINEERING**

- Highly suitable

**AGRICULTURE**

- Highly suitable

**FOOD & HEALTH**

- Widely used (reference to chemical resistance in cleaning areas may be necessary)

**FISHING INDUSTRY**

- Widely used (care in wet areas is required, gumboots more suitable for wet applications)

**FABRICATION**

- Highly suitable (steel midsole advised to protect against penetration)

**FORESTRY**

- Widely used

**TRANSPORT**

- Widely used

**MOTOR INDUSTRY**

- Highly suitable



## SAFETY JOGGER

- Fully breathable stylish safety jogger
- Mesh lining thick neoprene inner sole
- Composite toe cap - 200J
- EVA conforming sole tough & durable



**Black  
TSJB**

Sizes	7	8	9	10
TSJB- BLACK	TSJB-7	TSJB-8	TSJB-9	TSJB-10

Sizes	11	12	13
TSJB- BLACK	TSJB-11	TSJB-12	TSJB-13



**Team**

*expect the best*

**DESCRIPTION:** The benchmark in quality workboots

**PRODUCT CODE:** CSB(black) or CSS(suede)

## CLASSIC PULL ON SAFETY BOOT



### MATERIALS

**UPPER**

- High quality 1st cowhide leather with elastic sides

**INNER-SOLE**

- Extra thick Neoprene inner-sole for extra comfort

**OUTER-SOLE**

- Tough & durable Polyurethane outer-sole with excellent grip properties

**LINING**

- Soft hydrophobic lining to keep foot cool and dry

**TOE CAP**

- Steel toe cap

**PULL LOOPS**

- Strong woven pull loops for easy on/off application

### SPECIFICATIONS

**STANDARDS**

- Meets AS/NZS 9001:2008, AS/NZS 2210.3:2009 & EN345

**SPECIAL FEATURES**

- 145mm boot height for ankle protection  
- Elastic sides for easy on/off application

**SOLE**

- Maximum temperature 90°C (degrees celcius)  
- Oil and acid resistant Polyurethane sole

**TOE CAP**

- Steel toe cap - tested to an impact of 200 Joules

**SIZING/COLOURS**

- Available from Size 7 up to Size 12 (unisex sizing), in both Black Leather & Coated Leather

**LIFE SPAN**

- The use and application determines the life span of the boot. Normal environments should provide 12 months of use, if appropriate care is taken

### USES

**GENERAL**

- Highly suitable

**CONSTRUCTION**

- Widely used

**MINING**

- Widely used (care in wet areas is required, gumboots more suitable for wet applications)

**ENGINEERING**

- Highly suitable

**AGRICULTURE**

- Highly suitable

**FOOD & HEALTH**

- Widely used (reference to chemical resistance in cleaning areas may be necessary)

**FISHING INDUSTRY**

- Widely used (care in wet areas is required, gumboots more suitable for wet applications)

**FABRICATION**

- Highly suitable (steel midsole advised to protect against penetration)

**WASTE DISPOSAL**

- Widely used (steel midsole advised to protect against penetration)

**FORESTRY**

- Widely used

**TRANSPORT**

- Widely used

**MOTOR INDUSTRY**

- Highly suitable

**METAL INDUSTRY**

- Widely used (temperature limitations must be observed)





*expect the best*



## GRAFTER PULL ON CLASSIC SAFETY BOOT

- 145mm ankle height elastic sided pull on work boot
- Strong woven pull loops for easy on/off application
- High quality 1st cowhide leather
- Polyurethane direct moulded outer - sole
- Neoprene insole - heavy duty, extra thick for comfort
- Steel toe cap - 200J - S3
- Complies with EN345 Safety Footwear Standard
- Complies with AS/NZS 90012008
- Complies with AS/NZS 2210 32009



**Black**  
CSB



**Coated Leather**  
CSS

Sizes	7	8	9	10
CSB - BLACK	CSB-7	CSB-8	CSB-9	CSB-10
CSS-SUEDE	CSS-7	CSS-8	CSS-9	CSS-10

Sizes	11	12
CSB - BLACK	CSB-11	CSB-12
CSS-SUEDE	CSS-11	CSS-12

*expect the best*

**DESCRIPTION:** The benchmark in quality workboots

**PRODUCT CODE:** HTB(black) or HTS(suede)

## HIGH TOP ZIP UP SAFETY BOOT



### MATERIALS

UPPER	- High quality 1st cowhide leather	LINING	- Soft hydrophobic lining to keep foot cool and dry
INNER-SOLE	- Extra thick Neoprene inner-sole for extra comfort	TOE CAP	- Steel toe cap
OUTER-SOLE	- Tough & durable Polyurethane outer-sole with excellent grip properties	ZIP	- Strong industrial grade full length zip with velcro over flap

### SPECIFICATIONS

STANDARDS	- Meets AS/NZS 9001:2008, AS/NZS 2210.3:2009 & EN345
SPECIAL FEATURES	- 150mm boot height for extra ankle protection - Padded collar and tongue for extra comfort - Zip side release with overflap
SOLE	- Maximum temperature 90°C (degrees celsius) - Oil and acid resistant Polyurethane sole
TOE CAP	- Steel toe cap - tested to an impact of 200 Joules
SIZING/COLOURS	- Available from Size 7 up to Size 12 (unisex sizing), in both Black Leather & Coated Leather
LIFE SPAN	- The use and application determines the life span of the boot. Normal environments should provide 12 months of use, if appropriate care is taken

### USES

GENERAL CONSTRUCTION	- Highly suitable - Widely used
MINING	- Widely used (care in wet areas is required, gumboots more suitable for wet applications)
ENGINEERING	- Highly suitable
AGRICULTURE	- Highly suitable
FOOD & HEALTH	- Widely used (reference to chemical resistance in cleaning areas may be necessary)
FISHING INDUSTRY	- Widely used (care in wet areas is required, gumboots more suitable for wet applications)
FABRICATION	- Highly suitable (steel midsole advised to protect against penetration)
WASTE DISPOSAL	- Widely used (steel midsole advised to protect against penetration)
FORESTRY	- Widely used
TRANSPORT	- Widely used
MOTOR INDUSTRY	- Highly suitable
METAL INDUSTRY	- Widely used (temperature limitations must be observed)

**Team**

*expect the best*



## GRAFTER HIGH TOP ZIP UP SAFETY BOOT

- 150mm high zip up ankle work boot
- Padded collar and tongue with zip side release
- High quality 1st cowhide leather boot lined with soft hydrophobic material to keep the foot cool and dry
- Polyurethane outer sole, tough and durable with excellent grip properties
- Neoprene insole - heavy duty, extra thick for comfort
- Steel toes cap - 200J - S3
- Complies with AS/NZS 90012008 & AS/NZS 221032009



**Black  
HTB**



**Coated Leather  
HTS**

Sizes	7	8	9	10
HTB - BLACK	HTB-7	HTB-8	HTB-9	HTB-10
HTS-SUEDE	HTS-7	HTS-8	HTS-9	HTS-10

Sizes	11	12
HTB - BLACK	HTB-11	HTB-12
HTS-SUEDE	HTS-11	HTS-12



*expect the best*

**DESCRIPTION:** Built for the toughest conditions

**PRODUCT CODE:** INDBR (black/red)

## NON STEEL TOE GUMBOOT



### MATERIALS

**UPPER**

- Heavy duty PVC coated upper

**OUTER SOLE**

- Super tough PU outer-sole (red for extra visibility)

**INNER-SOLE**

- Thick Neoprene inner-sole for extra comfort

**LINING**

- Polyester inner lining

### SPECIFICATIONS

**STANDARDS**

- Meets AS/NZS 2210.3-2009 & EN345

**SPECIAL FEATURES**

- Extra length to ensure foot stays dry and safe

**SOLE**

- Maximum temperature 90°C (degrees celcius)  
- Oil/acid/solvent resistant PU outer-sole to -20°

**SIZING/COLOURS**

- Available from Size 5 up to Size 13 (unisex sizing), in Black/Red

**LIFE SPAN**

- The use and application determines the life span of the boot. Normal environments should provide 12 months of use, if appropriate care is taken

### USES

**GENERAL**

- Highly suitable

**CONSTRUCTION**

- Widely used

**MINING**

- Widely used

**ENGINEERING**

- Highly suitable

**AGRICULTURE**

- Highly suitable

**FOOD & HEALTH**

- Widely used (reference to chemical resistance in clearing areas may be necessary)

**FISHING INDUSTRY**

- Widely used (care in wet areas is required)

**FABRICATION**

- Highly suitable (steel midsole advised to protect against penetration)

**WASTE DISPOSAL**

- Widely used (steel midsole advised to protect against penetration)

**FORESTRY**

- Widely used

**TRANSPORT**

- Widely used

**MOTOR INDUSTRY**

- Highly suitable

**METAL INDUSTRY**

- Widely used (temperature limitations must be observed)



## NON STEEL TOE GUMBOOT

- Heavy Duty PVC coated industrial gumboot with polyester inner lining
- Super tough PU sole in colour for extra visibility
- Thick Neoprene insole for extra comfort
- Extra length to ensure foot stays dry and safe
- Resistant to 20 - Oil/Acid



Sizes	5	6	7	8	9
INDBR - BLACK/RED	INDBR-5	INDBR-6	INDBR-7	INDBR-8	INDBR-9

Sizes	10	11	12	13
INDBR - BLACK/RED	INDBR-10	INDBR-11	INDBR-12	INDBR-13



*expect the best*

# STEEL TOE GUMBOOT

**DESCRIPTION:** Built for the toughest conditions

**PRODUCT CODE:** INDBY (black/yellow)

## STEEL TOE GUMBOOT



### MATERIALS

<b>UPPER</b>	- Heavy duty PVC coated upper	<b>LINING</b>	- Polyester inner lining
<b>INNER-SOLE</b>	- Thick Neoprene inner-sole for extra comfort	<b>TOE CAP</b>	- Steel toe cap
<b>OUTER-SOLE</b>	- Super tough PU outer-sole (coloured for extra visibility)		

### SPECIFICATIONS

<b>STANDARDS</b>	- Meets AS/NZS 2210.3:2009 & EN345
<b>SPECIAL FEATURES</b>	- Extra length to ensure foot stays dry and safe
<b>SOLE</b>	- Maximum temperature 90°C (degrees celcius) - Oil/acid/solvent resistant PU outer-sole to -20°
<b>TOE CAP</b>	- Steel toe cap - tested to an impact of 200 Joules
<b>SIZING/COLOURS</b>	- Available from Size 5 up to Size 13 (unisex sizing), in Black/Yellow
<b>LIFE SPAN</b>	- The use and application determines the life span of the boot. Normal environments should provide 12 months of use, if appropriate care is taken

### USES

<b>GENERAL CONSTRUCTION</b>	- Highly suitable
<b>MINING</b>	- Widely used
<b>ENGINEERING</b>	- Widely used
<b>AGRICULTURE</b>	- Highly suitable
<b>FOOD &amp; HEALTH</b>	- Highly suitable
<b>FISHING INDUSTRY</b>	- Widely used (reference to chemical resistance in cleaning areas may be necessary)
<b>FABRICATION</b>	- Widely used (care in wet areas is required)
<b>WASTE DISPOSAL</b>	- Highly suitable (steel midsole advised to protect against penetration)
<b>FORESTRY</b>	- Widely used (steel midsole advised to protect against penetration)
<b>TRANSPORT</b>	- Widely used
<b>MOTOR INDUSTRY</b>	- Widely used
<b>METAL INDUSTRY</b>	- Highly suitable
	- Widely used (temperature limitations must be observed)



## STEEL TOE GUMBOOT

- Heavy Duty PVC coated industrial gumboot with polyester inner lining
- Super tough PU sole in colour for extra visibility
- Steel toe cap (INBY Only) and strong PVC upper
- Thick Neoprene insole for extra comfort
- Extra length to ensure foot stays dry and safe
- Complies with EN345 & AS/NZS 221032009 (INDBY Only)
- Resistant to 20 - Oil/Acid



Sizes	5	6	7	8	9
INDBY - BLACK/YELLOW	INDBY-5	INDBY-6	INDBY-7	INDBY-8	INDBY-9

Sizes	10	11	12	13
INDBY - BLACK/YELLOW	INDBY-10	INDBY-11	INDBY-12	INDBY-13



*expect the best*



## STOLITE ORIGINAL

- Fully Waterproof
- Stows Away
- Mesh Inner Lining
- Hem Toggle Adjustment
- Lightweight Nylon PU
- Concealed Hood
- Unique Seam Seal Technology
- Full Back Venting



**Dark Navy**  
STODNCLAR



**Navy**  
STOBROY



**Ruby**  
STORCS

Sizes	Xtra Small	Small	Medium	Large
DARK NAVY		T-STODNCLAR-S	T-STODNCLAR-M	T-STODNCLAR-L
NAVY	T-STOBROY-XS	T-STOBROY-S	T-STOBROY-M	T-STOBROY-L
RUBY		T-STORCS-S	T-STORCS-M	T-STORCS-L

Sizes	Xtra Large	2Xtra Large	3Xtra Large
DARK NAVY	T-STODNCLAR-XL	T-STODNCLAR-XXL	
NAVY	T-STOBROY-XL	T-STOBROY-XXL	T-STOBROY-XXXL
RUBY	T-STORCS-XL		



**Team**

*expect the best*



## STOLITE ORIGINAL TROUSER

- Fully Waterproof
- Stows Away
- Elastic Waist
- Zip Cuff Boot Opening
- Lightweight Nylon PU
- Adjustable Cuffs
- Unique Seam Seal Technology



**Navy  
STOTN**



**BLACK  
STOTB**

Sizes	Small	Medium	Large
NAVY	T-STOTN-S	T-STOTN-M	T-STOTN-L
BLACK	T-STOTB-S	T-STOTB-M	T-STOTB-L

Sizes	Xtra Large	2Xtra Large	3Xtra Large
NAVY	T-STOTN-XL	T-STOTN-XXL	T-STOTN-XXXL
BLACK	T-STOTB-XL	T-STOTB-XXL	T-STOTB-XXXL



*expect the best*



## STOLITE EXPLORER

- Fully Waterproof
- Stows Away
- Full Back Venting
- Hem Toggle Adjustment
- Lightweight Nylon PU
- Concealed Hood
- Unique Seam Seal Technology



Sizes	Xtra Small	Small	Medium	Large
BLACK	T-STOEXB-XS	T-STOEXB-S	T-STOEXB-M	T-STOEXB-L

Sizes	Xtra Large	2Xtra Large
BLACK	T-STOEXB-XL	T-STOEXB-XXL



## FISHING MATE JACKET

- Fully Waterproof
- Heavy Duty
- 3/4 Length
- Storm Flap
- Heavy Duty Zip
- Attached Hood
- Double Welded Seams for Extra Strength
- Made from PVC Coated Polyester



Sizes	Small	Medium	Large
NAVY/ROYAL BLUE	T-FMJ-S	T-FMJ-M	T-FMJ-L

Sizes	Xtra Large	2Xtra Large	3Xtra Large
NAVY/ROYAL BLUE	T-FMJ-XL	T-FMJ-XXL	T-FMJ-XXXL



*expect the best*



## SCHOOL YELLOW RAINCOAT

- Fully Waterproof
- Made from Strong Vinyl
- Safety Yellow Colour for Extra Visibility
- Attached Hood
- Double Welded Seams for Extra Strength
- 3/4 Length

 **Yellow  
SCH**

Sizes	4	6	8	10
<b>YELLOW</b>	T-SCH-4	T-SCH-6	T-SCH-8	T-SCH-10

Sizes	12	14	16
<b>YELLOW</b>	T-SCH-12	T-SCH-14	T-SCH-16

**Team**

*expect the best*



## SCHOOL CLEAR RAINCOAT

- Fully Waterproof
- Made from Strong Vinyl
- Clear Design For School Uniforms
- Attached Hood
- Double Welded Seams for Extra Durability
- 3/4 Length

● Clear  
SCL

Sizes	2	4	6	8
CLEAR	T-SCL-2	T-SCL-4	T-SCL-6	T-SCL-8

Sizes	10	12	14	16
CLEAR	T-SCL-10	T-SCL-12	T-SCL-14	T-SCL-16



*expect the best*



## SCHOOL REVERSIBLE RAINCOAT

- Fully Waterproof
- Reversible Design with Two Colours
- Laminated Vinyl for Extra Durability
- Attached Hood
- Double Welded Seams for Extra Durability
- 3/4 Length



**Navy/Yellow**  
628

Sizes	4	6	8	10
NAVY/YELLOW	T-628-4	T-628-6	T-628-8	T-628-10

Sizes	12	14	16
NAVY/YELLOW	T-628-12	T-628-14	T-628-16



## FEATHERWEIGHT RAINCOAT

- Fully Waterproof
- Windproof & Tearproof
- Safety Yellow Colour for Extra Visibility
- Attached Hood
- Lightweight PU
- Coated Polyester
- 3/4 Length



Sizes	2	4	6	8
YELLOW	T-FW-2	T-FW-4	T-FW-6	T-FW-8

Sizes	10	12	14	16
YELLOW	T-FW-10	T-FW-12	T-FW-14	T-FW-16



## V-LITE STOWAWAY RAIN JACKET

- Fully Waterproof
- Stows Away
- Windproof & Tearproof
- Concealed Hood
- Made from Lightweight Nylon for Heavy Bags
- Two Front Pockets



Sizes	6	8	10
NAVY/ROYAL	T-VLJNR-6	T-VLJNR-8	T-VLJNR-10

Sizes	12	14
NAVY/ROYAL	T-VLJNR-12	T-VLJNR-14





## V-LITE STOWAWAY TROUSER

- Fully Waterproof
- Stows Away
- Windproof & Tearproof
- Elastic Waist & Adjustable Cuffs
- Made from Lightweight Nylon for Heavy Bags
- Two Front Pockets



Sizes	6	8	10
NAVY	T-VLTN-6	T-VLTN-8	T-VLTN-10

Sizes	12	14
NAVY	T-VLTN-12	T-VLTN-14

**Electaserv**

**2019/20**



*expect the best*

**Electaserv**

**HEAD OFFICE & QUEENSLAND WAREHOUSE**

WAREHOUSE 2, 97 FREIGHT ST, LYTTON,  
QLD, 4178, AUSTRALIA

**VICTORIAN OFFICE**

2/11 BROUGH ST, SPRINGVALE, VIC, 3171

PHONE 1800 255 508      FAX 1800 640 073  
HEAD OFFICE 07 3906 2999      FAX 07 3906 2900

**AUSTRALIA WIDE REPRESENTATION**

A.B.N 15 009 687 076  
DIVISION OF ELECTRICAL AGENCIES PTY LTD  
EST. 1932

[sales@electaserv.com.au](mailto:sales@electaserv.com.au)

[www.electaserv.com.au](http://www.electaserv.com.au)